

HALF-YEARLY POST EC COMPLIANCE REPORT

OF

“Residential cum Commercial Project”

Survey No. 19 Hissa Nos. I, Survey No. 20, Survey No. 24

Hissa No. A/8/B and Survey No.25 Hissa No. I of Village:

Rohinjan Taluka: Panvel District: Raigad

PERIOD

January 2023 – June 2023

Project Proponent

M/s. Mahaavir Superstructures Pvt. Ltd.

Date: 02/09/2023



To
The Director
Regional Office (WCZ),
Ministry of Environment, Forest and Climate Change,
Nagpur

Ref.: No. SIA/MH/MIS/213444/2021

Subject: Submission of six-monthly monitoring report (January–June,2023) for “Mahaavir Superstructures Pvt. Ltd.” Proposed Residential cum Commercial project at Plot bearing Survey No. 19 Hissa Nos. 1, Survey No. 20, Survey No. 24A Hissa No. 8/B and Survey No.25 Hissa No. 1 of Village, Rohinjan Taluka Panvel District Raigad, Maharashtra.

Sir,

With reference to above subject, we would like to inform you that we have been accorded the environmental clearance for our Commercial project from SEIAA, Maharashtra on 21.12.2021. We hereby submit six monthly monitoring report for the period ended (January-June,2023) for building and construction project.

We hope that the above submission meets your expectation and request you to kindly give us receipt of submission of the same.

Thanking You,

Yours Faithfully,

For Mahaavir Superstructure Private Limited

Authorized Signatory

24/05/23
Maharashtra Pollution Control Board
Kalpataru Point, 2nd Floor, Sion Circle,
Opp. Cine Planet, Sion (East),
Mumbai - 400 022.
Tel. 24010437 / 24020781.
Website : www.mpcb.gov.in

CC: Member Secretary, SEIAA
Member Secretary, MPCB
Member Secretary, CPCB



Mahaavir Superstructures Pvt. Ltd.

Regd. Off.: A-1003 to 1009, "A" Wing, 10th Floor, Mahaavir Icon, Plot No. 89&90, Sector-15, CBD Belapur, Navi Mumbai- 400614.

CIN NO: U45400MH2019PTC322235

Tel: 022 62799300 | Email: sales@mahaavir.in | Website: www.mahaavir.in

DATA SHEET

OF

“Residential cum Commercial Project”

Survey No. 19 Hissa Nos. I, Survey No. 20,
Survey No. 24 Hissa No. A/8/B and Survey
No.25 Hissa No. I of Village: Rohinjan Taluka:
Panvel District: Raigad

PROJECT PROPONENT

M/s. Mahaavir Superstructures Pvt Ltd.

**Monitoring the Implementation of Environmental Safeguards Ministry of Environment & Forests
Western Region, Regional Office, Nagpur**

MONITORING REPORT

DATA SHEET

1.	Project type: river-valley/ mining/ Industry/thermal/ nuclear/ Other (specify)	Residential cum Commercial
2.	Name of the project	Proposed Residential cum Commercial Project on Survey No. 19 Hissa Nos. 1, Survey No. 20, Survey No. 24 Hissa No. A/8/B and Survey No.25 Hissa No. 1 of Village, Rohinjan Taluka Panvel District Raigad M/s. Mahaavir Superstructures Private Limited.
3.	Clearance letter (s) / OM/ no. and date:	SIA/MH/MIS/213444/2021 dtd. 21.12.2021.
4.	Location	Survey No. 19 Hissa Nos. I, Survey No. 20, Survey No. 24 Hissa No. A/8/B and Survey No.25 Hissa No. I of Village: Rohinjan Taluka: Panvel District: Raigad
a.	District (s)	Thane
b.	State (s)	Maharashtra
c.	Latitude / Longitude	Latitude - 19° 5'32.12"N, Longitude - 73° 4'49.79"E
5.	Address for correspondence	
a.	Address of concerned project Chief Engineer (with pin code & telephone / telex / fax numbers)	Office no 1003-1009, Wing A, 10 Floor, Mahaavir Icon, Sector 15, CBD Belapur, Navi Mumbai - 400614
b.	Address of Executive Project Engineer /Manager (with pin code / fax number)	Survey No. 19 Hissa Nos. I, Survey No. 20, Survey No. 24 Hissa No. A/8/B and Survey No.25 Hissa No. I of Village: Rohinjan Taluka: Panvel District: Raigad
6.	Salient features:	<u>Salient Features of the project:</u>

a.	of the project	Total Plot Area = 24055.00 sq.mt Total F.S.I = 64948.76 sq.mt. Total Non-F.S. I = 27612.24 sq.mt. Total Construction Area = 92561.00 sq.mt.
b.	of the environmental management plans	1. Sewage Treatment Plant: Sewage Treatment Plant with capacity 660 KLD will be provided for treating the wastewater. Recycled wastewater will be used for Flushing, gardening etc. 2. Rain Water Harvesting: Rain Water Harvesting shall be provided to raise the ground water table. One RWH tank of capacity of 125 cum 3. Solid Waste Management: The Wet waste will be processes in OWC for manure for landscaping & Gardening. The Dry waste will be handover to the recyclers. & The STP sludge will be used as manure for plantation. 4. Solar energy is used as back-up to main source including streets and buildings.
7.	Break Up Of the project Area	
a.	Submerge area: forest &: non-forest	Non-Forest
b.	Others	Nil.
8.	Breakup of the project affected: population with enumeration of those losing houses / dwelling units, only agriculture land only, both dwelling units and agriculture land and landless labours / artisan	The project does not envisage acquisition of land and / or displacement.
a.	SC, ST / Adivasis	---
b.	Others	---

DATA SHEET

Survey No. 19 Hissa Nos.11, Survey No. 20, Survey No. 24 Hissa No. A/8/B and Survey No.25 Hissa No. 1 of Village: Rohinjan Taluka: Panvel District: Raigad

	(Please indicate whether these figures are based on any scientific and systematic survey carried out or only provisional figures, if a survey is carried out give details and years of survey)	
9.	Financial details	
a.	Project cost as originally planned and subsequent revised estimates and the year of price reference	Total project cost: 164 Cr.
b.	Allocation made for environmental management plans with item wise and year wise break-up	Capital EMP Cost: 202 lakhs O&M Cost for EMP: 25 lakhs/annum
c.	Benefit cost ratio/ Internal rate of return and the year of assessment	---
d.	Whether (c) includes the cost of environmental management as shown in the above	---
e.	Actual expenditure incurred on the project so far	Rs. 80 Cr.
f.	Actual expenditure incurred on the environmental management plans so far	Nil
10.	Forest land required	
a.	The status of approval for diversion of forest land for non-forestry use	The land is of non-forest type hence not applicable.
b.	The status of clearing and felling	N.A
c.	The status of compensatory afforestation, if any	---
d.	Comments on the viability & sustainability of compensatory afforestation program in the light of actual field experience so far	N.A.
11.	The status of clear felling in non-forest areas (such as submergence area of	N.A.

DATA SHEET

Survey No. 19 Hissa Nos.11, Survey No. 20, Survey No. 24 Hissa No. A/8/B and Survey No.25 Hissa No. 1 of Village: Rohinjan Taluka: Panvel District: Raigad

	reservoir, approach roads), if any with quantitative information	
12.	Status of construction	
a.	Date of commencement (Actual and/or planned)	January 2022
b.	Date of completion (Actual and/or planned)	December, 2027.
13.	Reasons for the delay if the project is yet to start	N.A
14.	Dates of site visits	--
a.	The date on which the project was monitored by the regional office on previous occasions, if any	Not yet visited.
b.	Date of site visit for this monitoring report	--
15.	Details of correspondence with project authorities for obtaining action plans/information on status on compliance to safeguards other than the routine letters for logistic support for site visits	M/s. Mahaavir Superstructures Private Limited.

COMPLIANCE OF EC CONDITION

FOR

“Residential cum Commercial Project”

Survey No. 19 Hissa Nos. I, Survey No. 20, Survey No. 24 Hissa No. A/8/B and Survey No.25 Hissa No. I of Village: Rohinjan Taluka: Parnel District: Raigad

PROJECT PROPONENT

M/s. Mahaavir Superstructures Pvt. Ltd.

SIX MONTHLY COMPLIANCE REPORT

Office no 1003-1009, Wing A, 10 Floor, Mahaavir Icon, Sector 15,
CBD Belapur, Navi Mumbai -400614

Point wise compliance status to various stipulations laid down by the Government of Maharashtra as per the Environmental Clearance issued vide letter no. SIA/MH/MIS/213444/2021 dtd. 21.12.2021 as follows:

General Conditions:

Sr. No	COMPLIANCE	REPLY
SEAC Conditions		
1	PP to submit IOD/IOA/Concession Document/Plan Approval or any other form of documents as applicable clarifying its conformity with local planning rules and provisions thereunder as per the circular dated 30.01.2014 issued by the Environment Department, Govt. of Maharashtra.	We have obtained approved plan from Panvel Municipal corporation vide Letter No. PMC/TP/Rohinjan/19, 1, 20, 24/A/8/B/16030/1906/2021 dated 17.09.2021 for total built-up area 92561.00 sq.mt. (FSI Area: 64948.76 Sq. mt. and Non FSI Area: 27612.24 Sq. mt). Copy of approved plan attached as Annexure 01 .
2	PP to obtain following NOCs: a) Water Supply, b) Sewer NOC, c) SWM NOC, d) Storm Water Drain remarks, e) Tree NOC.	Condition is noted & we shall comply the same. NOCs attached as Annexure 02 .
3	PP to reduce the discharge of treated sewage to 35%. PP to submit NOC from concern authority for use of excess treated water in nearby Garden reservation/ Construction.	Condition is noted & PP is ensured to reduce the of treated sewage to 35%.
4	PP to provide Low Flow Devices (LFD) & Sensors as water conservation measures in operation phase; PP to provide portable STP for workers in construction phase & accordingly revise construction & operation phase EMP.	Condition is noted & we shall comply the same.
5	SEIAA after deliberation decided to grant EC for - FSI- 64948.76 m2, non-FSI- 27612.24 m2, Total BUA- 92561.00 m2. (Plan approval-	Condition is noted & we shall comply the same.

SIX MONTHLY COMPLIANCE REPORT

Office no 1003-1009, Wing A, 10 Floor, Mahaavir Icon, Sector 15,
CBD Belapur, Navi Mumbai -400614

Sr. No	COMPLIANCE	REPLY
	PMC/TP/Rohinjan/190, dated-17.09.2021).	
6	PP to submit revise energy calculation with terrace floor plan for installing solar panel.	Condition is noted & we shall comply the same.
7	Planning authority to ensure sewer lines & storm water drain network before issuing Occupation Certificate.	Condition is noted & we shall comply the same.
8	PP to remove use of treated water shown for vehicle washing in water balance chart & accordingly revise water balance.	Condition is noted & we shall comply the same.
SEIAA Conditions		
1	PP to strictly adhere to all the conditions mentioned in Maharashtra (Urban Areas) Protection and Preservation of Trees Act, 1975 as amended during the validity of Environment Clearance.	Condition is noted & we shall comply the same.
2	PP to keep open space unpaved so as to ensure permeability of water. However, whenever paving is deemed necessary, PP to provide grass pavers of suitable types & strength to increase the water permeable area as well as to allow effective fire tender movement.	Condition is noted & we shall comply the same.
3	PP to achieve at least 5% of total energy requirement from solar/other renewable sources.	Condition is noted & we shall comply the same. Refer Annexure 03.
4	PP Shall comply with Standard EC conditions mentioned in the Office Memorandum issued by MoEF& CC vide F.No.22-34/2018-IA.III dt.04.01.2019.	Condition is noted & we shall comply the same.
5	SEIAA after deliberation decided to grant EC for - FSI- 64948.76 m2,	Condition is noted & we shall comply the same.

SIX MONTHLY COMPLIANCE REPORT

Office no 1003-1009, Wing A, 10 Floor, Mahaavir Icon, Sector 15,
CBD Belapur, Navi Mumbai -400614

Sr. No	COMPLIANCE	REPLY
	non-FSI- 27612.24 m2, Total BUA- 92561.00 m2. (Plan approval- PMC/TP/Rohinjan/190, dated- 17.09.2021).	
General conditions-		
A] construction phase		
1	The solid waste generated should be properly collected and segregated. Dry/inert solid waste should be disposed of to the approved sites for land filling after recovering recyclable material.	Garbage will be collected manually from the construction workers and carted to collection spot through trolleys. In order to avoid problems associated with solid waste disposal problems, an effective solid waste management system will be followed by segregating the wet and dry garbage and handover it to the local authority for disposal.
2	Disposal of muck, Construction spoils, including bituminous material during construction phase should not create any adverse effect on the neighboring communities and be disposed taking the necessary precautions for general safety and health aspects of people, only in the approved sites with the approval of competent authority.	All construction waste gets collected and segregated properly. Most of that is reused for the construction activity.
3	Any hazardous waste generated during construction phase should be disposed of as per applicable rules and norms with necessary approvals of the Maharashtra Pollution Control Board.	Paint waste & used oil would be generated from the site, will be disposed through Authorized vendor of MPCB.
4	Adequate drinking water and sanitary facilities should be provided for construction workers at the site. Provision should be made for mobile toilets. The safe disposal of wastewater and solid wastes generated during	Adequate drinking water facility is provided for the workers at the site during construction phase.

SIX MONTHLY COMPLIANCE REPORT

Office no 1003-1009, Wing A, 10 Floor, Mahaavir Icon, Sector 15,
CBD Belapur, Navi Mumbai -400614

Sr. No	COMPLIANCE	REPLY
	the construction phase should be ensured.	
5	Arrangement shall be made that waste water and storm water do not get mixed.	Covered sewage system has been proposed which is connected to STP for the treatment and reuse of the treated water. Excess treated water shall be disposed-off into the sewer drain.
6	Water demand during construction should be reduced by use of pre-mixed concrete, curing agents and other best practices.	Tanker water is used for construction work.
7	The ground water level and its quality should be monitored regularly in consultation with Ground Water Authority.	There is no extraction of ground water proposed in the project.
8	Permission to draw ground water for construction of basement if any shall be obtained from the competent Authority prior to construction/operation of the project.	Used of only Tanker water for construction
9	Fixtures for showers, toilet flushing and drinking should be of low flow either by use of aerators or pressure reducing devices or sensor-based control.	Adequate measures will be taken into consideration to minimize the wastage of water.
10	The Energy Conservation Building code shall be strictly adhered to.	Agreed to comply with the Architect design at planning stage.
11	All the topsoil excavated during construction activities should be stored for use in horticulture I landscape development within the project site.	Excavated top soil will be used for landscaping.
12	Additional soil for levelling of the proposed site shall be generated within the sites (to	The cut & fill is minimum to the extent possible. The cut & fill is accordance with the natural contour and it will be maintained in such a way that the natural drainage will

SIX MONTHLY COMPLIANCE REPORT

Office no 1003-1009, Wing A, 10 Floor, Mahaavir Icon, Sector 15,
CBD Belapur, Navi Mumbai -400614

Sr. No	COMPLIANCE	REPLY
	the extent possible) so that natural drainage system of the area is protected and improved.	not disturb. There will not be import and export of soil from site.
13	Soil and ground water samples will be tested to ascertain that there is no threat to ground water quality by leaching of heavy metals and other toxic contaminants.	Soil testing was done, according to the reports all the parameters are within limit and so there is no threat to groundwater quality by leaching of heavy metals and other toxic contaminants
14	PP to strictly adhere to all the conditions mentioned in Maharashtra (Urban Areas) Protection and Preservation of Trees Act, 1975 as amended during the validity of Environment Clearance.	Condition is noted.
15	The diesel generator sets to be used during construction phase should be low Sulphur diesel type and should conform to Environments (Protection) Rules prescribed for air and noise emission standards.	About 2*500 KVA capacity DG set has used for backup during construction phase. These are environment friendly make and provided with acoustic enclosure to avoid noise emission.
16	PP to strictly adhere to all the conditions mentioned in Maharashtra (Urban Areas) Protection and Preservation of Trees Act, 1975 as amended during the validity of Environment Clearance.	Condition is noted.
17	Vehicles hired for transportation of Raw material shall strictly comply the emission norms prescribed by Ministry of Road Transport & Highways Department. The vehicle shall be adequately covered to avoid spillage/leakages.	It will ensure that all the vehicles used for construction activities are having valid Pollution under Check (PUC) certificates. The vehicles without valid Pollution under Check (PUC) certificate are not permitted at project site.

SIX MONTHLY COMPLIANCE REPORT

Office no 1003-1009, Wing A, 10 Floor, Mahaavir Icon, Sector 15,
CBD Belapur, Navi Mumbai -400614

Sr. No	COMPLIANCE	REPLY
18	Ambient noise levels should conform to residential standards both during day and night. Incremental pollution loads on the ambient air and noise quality should be closely monitored during construction phase. Adequate measures should be made to reduce ambient air and noise level during construction phase, so as to conform to the stipulated standards by CPCB/MPCB.	<p>Following care will be taken regarding noise levels with conformation to the residential area.</p> <ul style="list-style-type: none"> • Use of well-maintained equipment fitted with silencers. • Noise shields near the heavy construction operations are provided. • Construction activities are limited to daytime hours only. • Also, use of Personal Protective Equipment (PPE) like ear muffs and ear plug during construction activities.
19	Diesel power generating sets proposed as source of backup power for elevators and common area illumination during construction phase should be of enclosed type and conform to rules made under the Environment (Protection) Act, 1986. The height of stack of DG sets should be equal to the height needed for the combined capacity of all proposed DG sets. Use low sulphur diesel is preferred. The location of the DG sets may be decided with in consultation with Maharashtra Pollution Control Board.	<ul style="list-style-type: none"> • D.G. sets will be provided as back up for Residential buildings. • About 2*500 KVA D.G. set will be provided with silencer & acoustic enclosures. The stacks shall be provided as per MPCB norms.
20	Regular supervision of the above and other measures for monitoring should be in place all through the construction phase, so as to avoid disturbance to the surroundings by a separate environment cell /designated person.	Regular supervision done by our site engineer to take care of the construction activity and of the surroundings.
General conditions- B] Operation phase		

SIX MONTHLY COMPLIANCE REPORT

Office no 1003-1009, Wing A, 10 Floor, Mahaavir Icon, Sector 15,
CBD Belapur, Navi Mumbai -400614

Sr. No	COMPLIANCE	REPLY
1	<p>a) The solid waste generated should be properly collected and segregated. b) Wet waste should be treated by Organic Waste Converter and treated waste (manure) should be utilized in the existing premises for gardening. And, no wet garbage will be disposed outside the premises. c) Dry/inert solid waste should be disposed of to the approved sites for land filling after recovering recyclable material.</p>	<p>Garbage will be collected manually from each of the building and carted to collection spot through trolleys. In order to avoid problems associated with solid waste disposal problems, an effective solid waste management system will be followed by segregating the wet and dry garbage and handover it to the local authority for disposal.</p>
2	<p>E-waste shall be disposed through Authorized vendor as per E-waste (Management and Handling) Rules, 2016.</p>	<p>Yes, E-waste shall be disposed through Authorized vendor as per E-waste (Management and Handling) Rules, 2016</p>
3	<p>a) The installation of the Sewage Treatment Plant (STP) should be certified by an independent expert and a report in this regard should be submitted to the MPCB and Environment department before the project is commissioned for operation. Treated effluent emanating from STP shall be recycled/ reused to the maximum extent possible. Treatment of 100% grey water by decentralized treatment should be done. Necessary measures should be made to mitigate the odour problem from STP. b) PP to give 100 % treatment to sewage /Liquid waste and explore the possibility to recycle at least 50 % of water, Local authority should ensure this.</p>	<p>STP has been provided to treat the waste water. STP has been provided by established consultant and operation and maintenance shall be done by the technical persons of consultant. MOU will be done for the maintenance. Capacity of STP (KLD): 660 KLD provided which will be utilize for Flushing and Gardening purpose. Refer Annexure 04.</p>

SIX MONTHLY COMPLIANCE REPORT

Office no 1003-1009, Wing A, 10 Floor, Mahaavir Icon, Sector 15,
CBD Belapur, Navi Mumbai -400614

Sr. No	COMPLIANCE	REPLY
4	<p>Project proponent shall ensure completion of STP, MSW disposal facility, green belt development prior to occupation of the buildings. As agreed during the SEIAA meeting, PP to explore possibility of utilizing excess treated water in the adjacent area for gardening before discharging it into sewer line No physical occupation or allotment will be given unless all above said environmental infrastructure is installed and made functional including water requirement.</p>	<p>STP shall be provided for Recycling of wastewater. Proper disposal of waste will be done through well managed Solid Waste management team.</p>
5	<p>The Occupancy Certificate shall be issued by the Local Planning Authority to the project only after ensuring sustained availability of drinking water, connectivity of sewer line to the project site and proper disposal of treated water as per environmental norms.</p>	<p>Condition is Noted.</p>
6	<p>Traffic congestion near the entry and exit points from the roads adjoining the proposed project site must be avoided. Parking should be fully internalized and no public space should be utilized.</p>	<ul style="list-style-type: none"> • This effect would be prominent during construction as well as operation phase. The probability of inconvenience faced due to the frequency of truck movement during construction phase would be minimized by better control of traffic movement in the area. Noise levels expected from the planned operating conditions have been assessed and are likely to be within acceptable levels. The impacts have been mitigated by the suggested measures in the “air control and management section”. <p>Anti-honking sign boards are placed in the parking areas and on entry and exit point. The project will be provided with sufficient road facilities within the project premises and there will be a large area provided for the parking of vehicles.</p>

SIX MONTHLY COMPLIANCE REPORT

Office no 1003-1009, Wing A, 10 Floor, Mahaavir Icon, Sector 15,
CBD Belapur, Navi Mumbai -400614

Sr. No	COMPLIANCE	REPLY
7	PP to provide adequate electric charging points for electric vehicles (EVs).	We shall propose 25% of charging points for electric vehicles on total parking on the project
8	Green Belt Development shall be carried out considering CPCB guidelines including selection of plant species and in consultation with the local DFO/ Agriculture Dept.	The green area proposed is 3670.00 sq. mt. on the Ground A combination of native evergreen trees and ornamental flowering trees, shrubs and palms are planted in the complex. Trees have been planted of about 435 No's. Refer Annexure 05.
9	A separate environment management cell with qualified staff shall be set up for implementation of the stipulated environmental safeguards.	Separate environment management cell/ consultant with qualified staff is formed and implementing the same.
10	Separate funds shall be allocated for implementation of environmental protection measures/EMP along with item-wise breaks-up. This cost shall be included as part of the project cost. The funds earmarked for the environment protection measures shall not be diverted for other purposes.	EMP allocated for all pollution devices and other facilities. Refer Annexure 06. Capital EMP Cost: Rs. 202.00 Lakh O & M Cost: 25.00 Lakh/year
11	The project management shall advertise at least in two local newspapers widely circulated in the region around the project, one of which shall be in the Marathi language of the local concerned within seven days of issue of this letter, informing that the project has been accorded environmental clearance and copies of clearance letter are available with the Maharashtra Pollution Control Board and may also be seen at Website at parivesh.nic.in	The advertisement is published in Marathi language local newspaper. In Marathi newspaper 'Navshakti' dtd. 24.12.2021. & In English newspaper 'The Free Press Journal' dtd. 24.12.2021. Copy enclosed for your ready reference. Refer Annexure 07.

SIX MONTHLY COMPLIANCE REPORT

Office no 1003-1009, Wing A, 10 Floor, Mahaavir Icon, Sector 15,
CBD Belapur, Navi Mumbai -400614

Sr. No	COMPLIANCE	REPLY
12	Project management should submit half yearly compliance reports in respect of the stipulated prior environment clearance terms and conditions in hard & soft copies to the MPCB & this department, on 1st June & 1st December of each calendar year.	
13	A copy of the clearance letter shall be sent by proponent to the concerned Municipal Corporation and the local NGO, if any, from whom suggestions/representations, if any, were received while processing the proposal. The clearance letter shall also be put on the website of the Company by the proponent.	We shall comply the same.
14	The proponent shall upload the status of compliance of the stipulated EC conditions, including results of monitored data on their website and shall update the same periodically. It shall simultaneously be sent to the Regional Office of MoEF, the respective Zonal Office of CPCB and the SPCB. The criteria pollutant levels namely; SPM, RSPM. SO ₂ , NO _x (ambient levels as well as stack emissions) or critical sector parameters, indicated for the project shall be monitored and displayed at a convenient location near the main gate of the company in the public domain.	Condition is noted & we shall comply the same.

SIX MONTHLY COMPLIANCE REPORT

Office no 1003-1009, Wing A, 10 Floor, Mahaavir Icon, Sector 15,
CBD Belapur, Navi Mumbai -400614

Sr. No	COMPLIANCE	REPLY
C] General EC Conditions		
1	PP has to strictly abide by the conditions stipulated by SEAC& SEIAA.	Condition is noted
2	If applicable Consent for Establishment" shall be obtained from Maharashtra Pollution Control Board under Air and Water Act and a copy shall be submitted to the Environment department before start of any construction work at the site.	We have obtained Consent to Establish from MPCB. Refer
3	Under the provisions of Environment (Protection) Act, 1986, legal action shall be initiated against the project proponent if it was found that construction of the project has been stailed without obtaining environmental clearance.	Environmental Clearance is already obtained. Refer Annexure 08 . Obtained Consent to Establish. Refer Annexure 09 .
4	The project proponent shall also submit six monthly reports on the status of compliance of the stipulated EC conditions including results of monitored data (both in hard copies as well as by e-mail) to the respective Regional Office of MoEF, the respective Zonal Office of CPCB and the SPCB.	Condition is noted and submitted to regional office of MoEF. We are submitting herewith six-monthly reports to environment department, Mantralay & MPCB.
5	The environmental statement for each financial year ending 31 st March in Form-V as is mandated to be submitted by the project proponent to the concerned State Pollution Control Board as prescribed under the Environment (Protection) Rules, 1986, as	Condition is noted.

SIX MONTHLY COMPLIANCE REPORT

Office no 1003-1009, Wing A, 10 Floor, Mahaavir Icon, Sector 15,
CBD Belapur, Navi Mumbai -400614

Sr. No	COMPLIANCE	REPLY
	amended subsequently, shall also be put on the website of the company along with the status of compliance of EC conditions and shall also be sent to the respective Regional Offices of MoEF by e-mail.	
6	No further Expansion or modifications, other than mentioned in the EIA Notification, 2006 and its amendments, shall be carried out without prior approval of the SEIAA. In case of deviations or alterations in the project proposal from those submitted to SEIAA for clearance, a fresh reference shall be made to the SEIAA as applicable to assess the adequacy of conditions imposed and to add additional environmental protection measures required, if any.	Condition is noted.
7	This environmental clearance is issued subject to obtaining NOC from Forestry & Wild life angle including clearance from the standing committee of the National Board for Wild life as if applicable & this environment clearance does not necessarily imply that Forestry & Wildlife clearance granted to the project which will be considered separately on merit	As the site is not within the radius as define under the circular number and hence NOC is not applicable.

ANNEXURES

FOR

“Residential cum Commercial Project”

Survey No. 19 Hissa Nos. I, Survey No. 20,
Survey No. 24 Hissa No. A/8/B and Survey
No.25 Hissa No. I of Village: Rohinjan Taluka:
Panvel District: Raigad

PROJECT PROPONENT

M/s. Mahaavir Superstructures Pvt Ltd.

Recognised by Ministry of Environment and Forests (MoEF) / Central Pollution Control Board Govt. of India (CPCB)
and ISO/IEC 17025:2017 (NABL), ISO 9001:2015, ISO 45001 : 2018 and ISO 14001 : 2015 Certified Company**AMBIENT AIR QUALITY MONITORING ANALYSIS REPORT**

Report No.	: GESEC/PRO/2023-24/04/1095
Sample ID-	: GESEC/PRO/2023-24/04/1095
Date of Report	: 08/05/2023
Client	: M/s Mahaavir Superstructures Pvt. Ltd
Site	: Project Site
Address	: Village, Rohinjan Taluka Panvel District Raigad.
Date of Sampling	: 26/04/2023
Date of Analysis	: 27-29/04/2023

RESULTS OF ANALYSIS

Sr. No.	DESCRIPTION	UNIT	RESULT	NAAQS
01	DATE OF SAMPLING	DD/MM/YY	26/04/2023	
02	TEST LOCATION		Project site	
03	AMBIENT TEMPTURE (MAX/MIN)	°C	32.5/26.5	
04	RELATIVE HUMIDITY	%RH	64	
05	SAMPLING DURATION	Min	8 hrs	
06	PM ₁₀	µg/M ³	88.00	100
07	PM _{2.5}	µg/M ³	38.00	60
08	SO ₂	µg/M ³	24.50	80
09	NO _x	µg/M ³	32.80	80
10	CO (1 Hrs)	mg/M ³	0.40	4.0

REMARK/OBERVATIONS

NAAQS – National Ambient Air Quality Standards.

Monitoring results are well within the limits prescribed by NAAQS



V. Hande
Mr. Vinod Hande
(Technical Manager)
Reviewed & Authorized By

Terms and conditions

1. The report is refer only to the sample tested and not applies to the bulk.
2. The results shown in this test report may differ based on various factors including temperature, humidity, pressure, retention time etc.
3. The test report cannot be reproduced wholly or in part and cannot be used for promotional or publicity purpose without the written consent of laboratory, GESEC.
4. Samples will be retained for a period of seven (7) days after completion of analysis. Longer retention periods can be arranged, on request of the customer.
5. We strictly maintain the confidentiality of all test result of sample(s) collected by us/ supplied by customer and not revel to third party unless required by the statutory or legal requirement.
6. MoEF approved Lab by Govt. of India. From date. 16/02/2022 to 29/02/2024





Recognised by Ministry of Environment and Forests (MoEF) / Central Pollution Control Board Govt. of India (CPCB) and ISO/IEC 17025:2017 (NABL), ISO 9001:2015, ISO 45001 : 2018 and ISO 14001 : 2015 Certified Company

Ambient Noise Monitoring Report

Report No.	: GESEC/PRO/2023-24/04/1096
Sample ID-	: GESEC/PRO/2023-24/04/1096
Date of Report	: 08/05/2023
Client	: M/s Mahaavir Superstructures Pvt. Ltd
Site	: Project Site
Address	: Village, Rohinjan Taluka Panvel District Raigad
Date of Sampling	: 26/04/2023

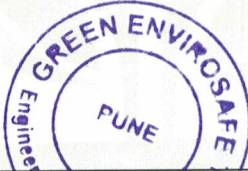
RESULTS OF ANALYSIS

Time	CPCB Limits	Main Gate
Day Time (dB) (6 A.M. – 10 P.M.)	55 dB	52.50
Night Time (dB) (10 P.M. – 6 A.M.)	45 dB	43.50
REMARK/OBERVATIONS NAAQS – Results are seems to be within limit		
		 Mr. Vinod Hande (Technical Manager) Reviewed & Authorized By

Terms and conditions

1. The report is refer only to the sample tested and not applies to the bulk.
2. The results shown in this test report may differ based on various factors including temperature, humidity, pressure, retention time etc.
3. The test report cannot be reproduced wholly or in part and cannot be used for promotional or publicity purpose without the written consent of laboratory, GESEC.
4. Samples will be retained for a period of seven (7) days after completion of analysis. Longer retention periods can be arranged, on request of the customer.
5. We strictly maintain the confidentiality of all test result of sample(s) collected by us/ supplied by customer and not revel to third party unless required by the statutory or legal requirement.
6. MoEF approved Lab by Govt. of India. From date. 16/02/2022 to 29/02/2024

Recognised by Ministry of Environment and Forests (MoEF) / Central Pollution Control Board Govt. of India (CPCB)
and ISO/IEC 17025:2017 (NABL), ISO 9001:2015, ISO 45001 : 2018 and ISO 14001 : 2015 Certified Company

SOIL ANALYSIS REPORT

CLIENT'S NAME	REPORT NO	GESEC/PRO/2023-24/04/1097
M/s Mahaavir Superstructures Pvt. Ltd Village, Rohinjan Taluka Panvel District Raigad.	DATED	08/05/2023
	DATE OF SAMPLING	26/04/2023
	DATE OF ANALYSIS	27-29/04/2023

RESULTS OF ANALYSIS

Sr. no	Parameters	Unit	Project Site
1	pH	-	7.80
2	Bulk Density	gm/cm3	1.30
3	Water Holding Capacity	%	48.0
4	Organic matter	%	1.2
5	Calcium	mg/kg	22.0
6	Chlorides	mg/kg	32.0
7	Magnesium	mg/kg	28.0
8	Sulphate	mg/kg	36.0
9	Available Phosphorous	mg/kg	0.60
10	Sodium	mg/kg	14.0
11	Potassium	mg/kg	22.0
12	Copper	mg/kg	0.80
13	Iron	mg/kg	18.2
14	Lead	mg/kg	<2.0
15	Zinc	mg/kg	1.0
16	Chromium	mg/kg	0.04



V. Hande

Mr. Vinod Hande
(Technical Manager)
Reviewed & Authorized By

Terms and conditions

1. The report is refer only to the sample tested and not applies to the bulk.
2. The results shown in this test report may differ based on various factors including temperature, humidity, pressure, retention time etc.
3. The test report cannot be reproduced wholly or in part and cannot be used for promotional or publicity purpose without the written consent of laboratory, GESEC.
4. Samples will be retained for a period of seven (7) days after completion of analysis. Longer retention periods can be arranged, on request of the customer.
5. We strictly maintain the confidentiality of all test result of sample(s) collected by us/ supplied by customer and not revel to third party unless required by the statutory or legal requiremen
6. MoEF approved Lab by Govt. of India. From date. 16/02/2022 to 29/02/2024



PANVEL MUNICIPAL CORPORATION

Tal.- Panvel, Dist.- Raigad, Panvel – 410 206.

E mail panvelcorporation@gmail.com

Tel - (022) 27458040/41/42

No.PMC/TP/Rohinjan/19/1, 20, 24/A/8/B/16030/2021

Date : १७ / ०८ / 2021

To,

M/s. Mahaavir Superstructures Pvt. Ltd.
Through Mohanish Omprakash Chhajer,
P.O.A.H. Praveen Kumar Uttamchand Miglani,
At.- Rohinjan, Tal. Panvel, Dist. Raigad.

SUB :- Amended Development Permission for Residential cum Commercial Building on Survey No.- 19/1, 20, 24/A/8/B, At.- Rohinjan, Tal.- Panvel, Dist.- Raigad.

REF :- 1) Your Architect's application no. 5310, Dated 12/03/2021.
2) Provisional Fire NOC issued by PMC Fire Officer vide letter No. PMC/Fire/2121/Ref.No.105/2409/2021, Dated 10/08/2021.
3) Height Clearance NOC issued by AAI vide letter No. NAVI/WEST/B/071919/416605, Dated 19/07/2019.

Sir,

Please refer to your application for Amended Development Permission for Residential cum Commercial Building on Survey No.- 19/1, 20, 24/A/8/B, At.- Rohinjan, Tal.- Panvel, Dist.- Raigad.

The Amended Development permission is hereby granted to construct Residential cum Commercial Building on the plot mentioned above.

The Developers / Builders / Owners shall take all precautionary measures for prevention of Malaria breeding during the construction period of the project. If required, you can approach Health Department PMC, for orientation program and pest control at project site to avoid epidemic.

You have to pay the necessary charges due to GST if applicable in future as per Panvel Municipal Corporation policy and as informed to you in writing and if not paid the permission granted will be revoked.

You will ensure that the building materials will not be stacked on the road during the construction period.

It is well aware that the State of Maharashtra is threatened with the spread of COVID-19 Virus and therefore, to take certain emergency measures to prevent and contain the spread of the virus the Govt. of Maharashtra & Hon. Commissioner, PMC issued the guidelines from time to time. Considering these facts, this C.C. / Plinth checked Certificate / O.C. is issued, subject to strict compliance of terms & conditions as mentioned in Annexure-A attached herewith.

Thanking you,

मा. आयुक्त यांचे मंजूरी नुसार

Assistant Director of Town Planning
Panvel Municipal Corporation

C.C.TO:- 1) Architect,
Ar. Adinath V. Patkar,
O7 Associates,
Shop No. 7, 8, Sai Prasad CHS,
Panvel 410 206.





PANVEL MUNICIPAL CORPORATION

Tal.- Panvel, Dist.- Raigad, Panvel – 410 206.

E mail – panvelcorporation@gmail.com

Tel – (022) 27458040/41/42

No.PMC/TP/Rohinjan/19/1, 20, 24/A/8/B/16030/9006/2021

Date : 30/08/2021

AMENDED COMMENCEMENT CERTIFICATE

Permission is hereby granted under section – 45 of the Maharashtra Regional and Town Planning Act.1966 (Maharashtra XXXVII of 1966) to, **M/s. Mahaavir Superstructures Pvt.Ltd. Through Mohanish Omprakash Chhajer P.O.A.H. Praveen Kumar Uttamchand Miglani.** As per the approved plans and subject to the following conditions for the development work of the **Proposed Residential cum Commercial Building (Building No. A- Ground + 29 Upper Floor, Building No. B, C, D, E & F- Ground + 22 Upper Floor)** on Survey No.- 19/1, 20, 24/A/8/B, At.- Rohinjan, Tal.- Panvel, Dist.- Raigad. (Plot Area = 24055.00 Sq.mt., Proposed Residential Built Up Area = 64573.56 sq.mt., Commercial Built Up Area = 375.20 sq.mt., Total Built Up Area = 64948.76 sq.mt.)

(No. of Residential Unit – 968 Nos., No. of Commercial Unit – 12 Nos.)

This Commencement Certificate is issued subject to condition that the applicant has to submit the Environmental Clearance Certificate before starting any construction work on the said plot.

1. **This Certificate is liable to be revoked by the Corporation if:-**
 - 1(a) The development work in respect of which permission is granted under this certificate is not carried out or the use thereof is not in accordance with the Sanctioned plans.
 - 1(b) Any of the conditions subject to which the same is granted or any of the restrictions imposed upon by the corporation is contravened.
 - 1(c) The commissioner is satisfied that the same is obtained by the applicant through fraud or Misrepresentation and the applicant and / or any person deriving title under him, in such an event shall be deemed to have carried out the development work in contravention of section – 43 or 45 of the Maharashtra Regional and Town Planning Act- 1966.
2. **The applicant shall:-**
 - 2(a) The Owner / Applicant shall give intimation in the prescribed form in Appendix-F of UDCPR 2020 after the completion of work up to plinth level.
 - 2(b) Give written notice to the Corporation regarding completion of the work.
 - 2(c) Permit authorized officers of the Corporation to enter the building or premises for which the permission has been granted, at any time for the purpose of ensuring the building control Regulations and conditions of this certificate.
 - 2(d) Obtain Occupancy Certificate from the Corporation.
3. The structural design, building materials, installations, electrical installations etc. shall be in accordance with the provision (except for provision in respect of floor area ratio) as prescribed in the National Building Code.
The Commencement Certificate shall remain valid for a period of 1 year from the date of issue and can be further revalidated as required under provision of section 48 of MRTP Act.- 1966. This Commencement Certificate is renewable every year but



such extended period shall be in no, case exceed three years provided further that such lapse shall not be any subsequent applicant for fresh permission under Section 44 of the Maharashtra Regional & Town Planning Act. 1996.

5. The conditions of this certificate shall be binding not only on the applicant but also on its successors and/or every person deriving title through or under him.
6. Prior Permission is necessary for any deviation / Change in Plan.
7. The applicant shall install the Rain Water Harvesting system as per UDD's notification No. TPB/432001/2133/CR-230/01/UD-II, Dated 10/03/2005 & section 13.3 of UDCPR- 2020.
 - a) The owner/society of every building mentioned in the (a) above shall ensure that the Rain water harvesting System is maintained in condition for storage of water for non-potable purposes or recharge of groundwater at all times.
 - b) The Authority may impose a levy of not exceeding Rs. 1000/- per annum for every 100 Sq. m. of built up area for the failure of the owner of any building mentioned in the (a) above to provide or to maintain Rain water Harvesting structures as required under these regulations. Failure to provide Rain Water Harvesting System shall be deemed as breach of the conditions on which the development permission has been granted.
8. As per provisions of section 13.2, 13.4, 13.5 of UDCPR- 2020, the applicant / owner / developer shall install SWH / RTPV, Grey Water Recycling Plant and solid waste management system and requisite provisions shall be made for proper functioning of the system.
9. **Action should be taken as per Section 42A (2) of Maharashtra Land Revenue Act, 1966.**
10. The applicant and The Architect shall strictly adhere to the condition mentioned in Fire NOC.
11. The applicant shall obtain all the necessary final NOC's / completion certificates / clearance relating to water supply, sewerages, SWD, Tree, CFO etc. from Panvel Municipal Corporation/CIDCO and submit the same to Panvel Municipal Corporation before applying for Occupancy Certificate for the building on the land under reference.
12. As per UDCPR-2020 Clause No. 3.1.1 (ii) The applicant shall obtained No objection certificate from the Irrigation department.
13. This Commencement Certificate issued to subject to condition that owner of the said plot to obtain Sub-plot Demarcation plan from the competent Authority.
14. The applicant shall develop RG areas and shall plant and maintained the required number of trees in the RG area as per UDCPR's and shall submit final NOC from the Tree Authority before applying for Occupancy Certificate.
15. Recreation ground or amenity open space be developed before applying for Building Completion Certificate.
16. No work should be started unless the existing structures area to be demolished with utmost care.
17. The Owner & the Architect and Structural Engineer concerned are fully responsible for the construction quality of the building as per approved building plan. Structural design, Stability building construction quality, which should confirm to with stand an earthquake of highest intensity in seismic zone IV.
18. The building constructed should not be occupied without obtaining Occupation Certificate. Otherwise it will be treated as unauthorized use and necessary action as per law will be taken.



19. The Owner & the architect are fully responsible for any Ownership. Area & Boundary disputes. In case of any dispute Panvel Municipal Corporation will not be responsible.
20. F.S.I. Calculation submitted in the drawings shall be as per Development Control Rules. If any discrepancy observed, the Architect will be held responsible and liable for necessary action.
21. The applicant shall be fully responsible for any Court Matter if pending in the Court and the order from Hon. Court shall be binding on the applicant.
22. In case of revised permission wherever third party interest is created by way of registered agreement to sale or lease etc. of the apartment, concern of such interest party / person as specified under RERA act. shall be submitted.
23. The applicant shall be fully responsible if any objection raised by the flat owner to whom applicant has sold the unit as per previous Commencement Certificate.
24. It is Mandatory to provide Temporary Toilet to labourers at site during construction period.
25. It is mandatory for the institution to take safety measures while the construction is under progress with respect to the educational activities going on in the respective site.
26. It is mandatory that the Natural course of water flowing through the plot should be channelized and maintained by the applicant.
27. As per Govt. of Maharashtra memorandum vide No.TBP/4393/1504/C4-287/94,UD-11/RDP, Dt.19th July, 1994 for all buildings following additional conditions shall apply.
 - i) As soon as the development permission for new construction or re-development is obtained by the Owners/Developer, he shall install a 'Display Board' on the conspicuous place on site indicating following details ;-
 - a) Name and address of the owner/developer, Architect and Contractor.
 - b) Survey Number/City survey Number, Plot Number/Sector & Node of Land under reference along with description of its boundaries.
 - c) Order Number and date of grant of development permissions or re-development permission issued by the Planning Authority or any other authority.
 - d) Number of Residential flats/Commercial Units with areas.
 - e) Address where copies of detailed approved plans shall be available for inspection.
 - ii) A notice in the form of an advertisement, giving all the detailed mentioned in (i) above, shall be published in two widely circulated newspapers one of which should be in regional language.
28. As per the notification dtd. 14th September 1999 and amendment on 27th August 2003, issued by Ministry of Environment & Forest (MOEF), Govt. of India and as per Circular issued by Urban Development Dept., Govt. of Maharashtra, vide No. FAR/102004/160/P.No.27/UD-20, dtd. 27/02/2004, for all Buildings following additional conditions shall apply.

The owners / Developers shall use fly ash Bricks or Blocks or Tiles or Clay fly ash Bricks or cement fly ash bricks or blocks or similar products or a Combination of aggregate of them to the extent of 100% (by volume) of the total bricks, blocks & Tiles as the case may be in their construction activity.
29. The building material in reconstruction case or soil removed from the trenches should not be dumped or stored on municipal road. It should be dumped or stored on site as would be decided by the concern Ward Officers of Panvel Municipal Corporation.



30. The applicants should fulfill all the health related provisions mentioned in the "Implementation of Ant larval & Mosquito Prevention Activities during and after construction and Tree Authority Bye-Laws 1966" The special mention is for mosquito prevention activities, construction of over-head tanks, debris removal and the sanitary conditions of drainage etc.
31. Workers should be accommodated at a distance of 25 to 35 feet from the protective walls of adjacent buildings on all sides of the construction site and also from the place where excavation has started. The developer should also arrange accommodation as per the standard in Section 34 of the Building and Other Construction Workers (Employment Regulation and Conditions of Service) Act, 1996.
- Accommodation :-
1. The employer shall provide, free of charges and within the work site or as near to it as may be possible, temporary living accommodation to all building workers employed by him for such period as the building or other construction work is in progress.
 2. The temporary accommodation provided under sub-section (1) shall have separate cooking place, bathing, washing and lavatory facilities.
 3. As soon as may be, after the building or other construction work is over, the employer shall, at his own cost, cause removal or demolition of the temporary structures erected by him for purpose of providing living accommodation cooking place or other facilities to the building workers as required under sub-section (1) and restore the ground in good level and clean condition.
 4. In case an employer is given any land by a Municipal Board or any other local authority for the purposes of providing temporary accommodation for the building workers under this section, he shall, as soon as may be after the construction work is over, return the possession of such land in the same condition in which he received the same.
32. The workers' quarters should be 25 to 35 feet away from the trees on the construction site so that if the tree falls, the workers' residence will not be endangered.
33. Special care should be taken to ensure that the colony on the construction site is not endangered by electricity and fire.
34. In construction sites where rivers, streams, nallas and natural water streams are in operation, special care should be taken for the safety of the workers and their place of residence should be 50 feet away from such streams.
35. Those working on the construction site must be registered under Section 15 of the "Building and Other Construction (Employment Regulation and Conditions of Service) Act, 1996"
- Section :- 15 Register of beneficiaries :- Every employer shall maintain a register in such form as may be prescribed showing the details of employment of beneficiaries employed in the building or other construction work undertaken by him and the same may be inspected without any prior notice by the secretary of the board or any other officer duly authorized by the board in this behalf.
36. Special care should be taken that workers not registered with the Maharashtra Building and Other Construction Workers Welfare Board will not work on the site.
37. A joint meeting of the developers and contractors of the Municipal Corporation and the municipal limits should be convened to take special care of the safety of the workers and to make the developers aware of the provisions of the Workers' Safety Act.
38. The developer will be obliged to take out accident insurance for the workers so that they are not deprived of the benefits they get in the event of an accident at work.



39. The design of the septic tank will be in accordance with the design of (IS-2470 & UDCPR- 2020), which will be binding on the developer / Architects and his successors. (If Applicable)
40. You will be required to get the design of your septic tank approved by the Sewage Department, Panvel Municipal Corporation. (If Applicable)
41. The Manual Scavenging Act 2013 prohibits the activities of manual scavenging. Therefore the applicant shall submit undertaking before applying for Occupancy Certificate, stating that you will not violate the said law.
42. The applicant is required to construct the discharge line at his own cost.
43. The applicant should set up electrical vehicle charging point in the said plot.
44. **As per Government notification no. टिपीएस/१८२०/अनौ.२७/प्र.क्र.८०/२०/नवि-१३, dated 14/01/2021, the applicant has availed the benefit of 50% discount on Ancillary and Premium charges in this project. Accordingly, the applicant has submitted affidavit dated 15/09/2021 and agreed to fulfill all term & conditions mentioned there in. All these terms & condition will be bind on owner / builder his heirs & successors.**
45. The applicant has to inform / update, Panvel Municipal Corporation & other concerned authorities regarding fulfillment of all terms & conditions as per Government notification no. टिपीएस/१८२०/अनौ.२७/प्र.क्र.८०/२०/नवि-१३, on dated 14/01/2021.
46. This set of Plans supersedes earlier approved plans vide letter dated 30/08/2019.

Note: - You have to pay the necessary charges due to GST if applicable in future as per Panvel Municipal Corporation policy and as informed to you in writing and if not paid the permission granted will be revoked.

मा. आयुक्त यांचे मंजूरी नुसार

Assistant Director of Town Planning
Panvel Municipal Corporation

C.C.TO:- 1) M/s. Mahaavir Superstructures Pvt. Ltd.
Through Mohanish Omprakash Chhajer,
P.O.A.H. Praveen Kumar Uttamchand Miglani,
At.- Rohinjan, Tal. Panvel, Dist. Raigad.

2) Architect,
Ar. Adinath V. Patkar,
O7 Associates,
Shop No. 7, 8, Sai Prasad CHS,
Panvel 410 206.

3) Ward Officer,
Prabhag Samati 'A, B, C, D'
Panvel Municipal Corporation, Panvel.

4) Tahasildar, Panvel for information & requested to take converted N.A. Tax within 30 days from date of issue of Commencement Certificate of Panvel Municipal Corporation.



Annexure-A

1. All terms & conditions mentioned in Government's order dated 02/05/2020, 03/05/2020, 05/05/2020, 19/05/2020 & 31/05/2020 read with PMC's circular dated 05/05/2020 & others are binding on applicants, Architects, Contractors, Suppliers, Company & its Directors, Owners, Developers & Builders etc.
2. If it is found that there is breach of terms & conditions or violations of terms/conditions of Government's order dated 02/05/2020, 03/05/2020, 05/05/2020, 19/05/2020, 31/05/2020 & 01/06/2020 read with PMC's circular dated 05/05/2020 & others you will be liable to prosecute under section 51 to 60 of Maharashtra Disaster Act, 2005 & Section 188 of Indian Penal Code, 1860.
3. These construction activities are allowed only in situ construction where workers are available in situ and no workers to be travel from outside on site for day to day work.
4. Wearing of face cover is compulsory in all work places and adequate stock of such face covers shall be made available.
5. All persons in charge of work places shall ensure social distancing as per the guidelines issued by Ministry of Health and Family Welfare, both within the work places.
6. Social distancing at work places shall ensure through adequate gaps between shifts, staggering the lunch breaks of labours, supervisors etc.
7. Provision for thermal scanning, hand wash and sanitizer preferably with touch free mechanism will be made at all entry and exit points and common areas. In addition, sufficient quantities of hand wash and sanitizer shall be made available in the work places / sites.
8. Frequent sanitization of entire workplace, common facilities and all points which come into human contact e.g. door handles etc., shall be ensured, including between shifts.
9. Persons above 65 years of age, persons with co-morbidities, pregnant women and children below the age of 10 years shall at home.
10. Use of Arogya Setu App shall be mandatory for all labours, supervisors etc. It shall be the responsibility of Developers & Architect to ensure 100% coverage of this app among the all labours, supervisors.
11. Large physical meetings to be avoided.
12. Hospital / clinics in the nearby areas, which are authorized to treat COVID-19 patients, should be identified and list should be available at work place all the times. Employees showing any symptoms of COVID-19 should be immediately sent for check up to such facilities. Quarantine areas should be earmarked for isolating employees showing symptoms till they are safely moved to the medical facilities.
13. Arrangement's for transport facilities shall be ensured with social distancing, wherever personal / public transport is not feasible.
14. Intensive communication and training on good hygiene practices shall be taken up.
15. This permission stands to be revoked from the date of declaration of area of work i.e. where construction activities are permitted, as containment zone at any time hereafter by the District Collector, Raigad or any other officer authorized by him, Commissioner, PMC's work needs to be suspended immediately without assigning any reason and without awaiting direction from Municipal Commissioner, PMC.
16. Necessary travel passes beyond PMC limit to be arranged by applicant
17. Medical check-up of all the labours and staff to be employed on work shall be carried out before allowing them on worksite & every week on work site.
18. All the undertakings submitted by you with your application are binding upon the applicant.

Water Nocs

Sewerage Remark



पनवेल महानगरपालिका

ता. पनवेल, जि. रायगड, पिन नं. ४१० २०६

कार्यालय : २७४५८०४०/४१/४२ फॅक्स नं. : ०२२-२७४५२२३३ Email : panvelcorporation@gmail.com

कार्यालय जा.क्र. पमपा/पा.पु.वि/६७२१/प्र. क्र. / ६२६/२०२१ दि. २१/११/२०२१

ना - हरकत दाखला

दाखला देण्यात येतो की, मे महावीर सुपर स्ट्रक्चर्स प्रा. लि. यांचे मार्फत मौजे रोहिंजण ता. पनवेल, जि. रायगड येथील स. न. १९, हि. नं. १, स. नं. २० हि. न. ० व स. नं. २४/अ, हि. नं. ८/ब या जागेत बांधण्यात येणा-या नियोजित इमारतींना सद्यस्थितीत पनवेल महानगरपालिकेकडून पाणी पुरवठा उपलब्ध होऊ शकत नाही परंतु पनवेल महानगरपालिकेस नविन अमृत पाणी पुरवठा योजनेमधून महाराष्ट्र जीवन प्राधिकरणाकडून २०. द.ल.लि. पाणी पुरवठा उपलब्ध होणार आहे. सदरची योजना पुर्ण झाल्यानंतर आवश्यक तो पाणी पुरवठा उपलब्ध करून देणे शक्य होईल.

(संजय जगताप)
शहर अभियंता
पनवेल महानगरपालिका



पनवेल महानगरपालिका

ता. पनवेल जि. रायगड पनवेल ४१०२०६

Email Id : panvelcorporation@gmail.com contact no. २२२७४५८०४०/४१/४२ website -www.panvelnagarparishad.com

जा.क्र.पमपा/मल./३५२१/प्र.क्र.०२/२२६/ २०२१ दिनांक:- २३/११/२०२१

प्रति,
संचालक,
महावीर सुपरस्ट्रक्चर प्रा.लि.
ए-विंग, दहावा मजला, महावीर आयकॉन,
फ्लॉट नं.८९ आणि ९०, सेक्टर-१५,
सी.बी.डी. बेलापुर, नवी मुंबई-४००६१४.

विषय :- मलनिःस्सारणासाठी ना हरकत दाखला मिळणेबाबत.

संदर्भ :- १) आपले पत्र क्र. निरक, दिनांक २३/०६/२०२१ या कार्यालयात प्राप्त दि. २५/०६/२०२१.
२) या कार्यालयाचे पत्र जा.क्र.पमपा/मल./३५२१/प्र.क्र.०२/१६९/२०२१ दि. ३१/०८/२०२१
३) आपले पत्र क्र. निरक, दिनांक २३/०६/२०२१ या कार्यालयात प्राप्त दि. २५/०६/२०२१.

संदर्भिय विषयाबाबत आपला अर्ज या कार्यालयामध्ये प्राप्त झाला आहे. सदर बाबत आपणास कळविण्यात येते की, आपण नमुद केलेल्या सर्वे नं.१९ हि.न.१, सर्वे नं.२०, हि.नं.० व सर्वे नं.२४/अ, हि.न.८/ब या जागेत नव्याने बांधण्यात येणा-या नियोजित इमारतीसाठी मलनिःस्सारणचा ना हरकत दाखला खालील नमुद अटी व शर्तीच्या अधिन राहून देण्यात येत आहे.

- अर्जदार यांनी स्वखर्चाने आवश्यक त्या क्षमतेचा मलप्रक्रिया केंद्र (STP) बांधणे व त्याची कायम देखभाल, दुरुस्ती करणे बंधनकारक राहिल.
- मलप्रक्रिया केंद्र बांधणेपूर्वी त्याचे Design हे सल्लागाराकडून करून त्यासाठी आवश्यक असणारे Consent to Establish व बांधलेनंतर Consent to Operate प्रमाणपत्र महाराष्ट्र प्रदुषण मंडळाकडून (MPCB) घेणे बंधनकारक राहिल.
- मलप्रक्रिया केंद्रामधुन प्रक्रिया केलेले सांडपाण्याचा पुनरवापर करणे बंधनकारक राहिल.
- मलमिश्रित पाण्यावर प्रक्रिया बाबत MPCB/CPCB चे याबाबत असलेले नियम लागू राहतील.
- मलप्रक्रिया केंद्रामुळे कोणतेही सार्वजनिक हितास बाधा येणार नाही तसेच सदरचे परिसरात दुर्गंधी व अस्वच्छता होणार नाही याची दक्षता घेणे आवश्यक आहे.
- भविष्यात पनवेल महानगरपालिकेने आपल्या नियोजित प्रकल्पाच्या शेजारी मलनिःस्सारण वाहिनीचे जाळे तयार केल्यास आपण आवश्यक ते शुल्क भरून त्याची जोडणी करणे बंधनकारक राहिल.
- नियोजन प्राधिकरणाने दिलेल्या बांधकाम परवानगीमधील सर्व शर्ती/अटी अर्जदार यांना बंधनकारक राहतील.
- शासनाचे पर्यावरण विभागाकडील संबंधित परिपत्रकाचे, शासन नियमांचे सर्व शर्ती/अटी अर्जदार यांना बंधनकारक राहतील. त्याचे उल्लंघन होणार नाही याची अर्जदार यांनी दक्षता घेणेत यावी.
- सदर जागेबाबत कोणत्याही न्यायालयात/प्राधिकरणासमोर कोणत्याही प्रकारचा दावा/वाद चालू असल्यास त्याची जबाबदारी अर्जदार/जमीन मालक यांची राहिल.

१०. अर्जदार यांनी सादर केलेली माहिती/कागदपत्रे खोटी अथवा दिशाभूल करणारी असल्यास सदर परवानगी रद्द समजण्यात येईल.
सबब सदर नाहरकत दाखला वरील नमुद अटी व शर्ती यांना अधिन राहून देण्यात येत आहे.

शहर अभियंता
पनवेल महानगरपालिका



पनवेल महानगरपालिका

ता. पनवेल, जि. रायगड, पिन नं. ४१० २०६

कार्यालय : २७४५८०४०/४१/४२ फॅक्स नं. : ०२२-२७४५२२३३ Email : panvelcorporation@gmail.com

कार्यालय जा.क्र. पमपा/बांधकाम.वि/- /प्र. क्र. - २८२५/२१

दि. २३/११/२०२१

ना - हरकत दाखला

मे महावीर सुपर स्ट्रक्चर्स प्रा. लि. यांचे मार्फत मौजे रोहिंजण ता. पनवेल, जि. रायगड येथील स. न. १९, हि. नं. १, स. नं. २० हि. न. ० व स. नं. २४/अ, हि. नं. ८/ब या जागेत बांधण्यात येणा-या नियोजित इमारतींना खालील अटी व शर्तीच्या अधिन राहून ना- हरकत दाखला देण्यात येत आहे.

- १) भूखंडातील स्टॉर्म वॉटर ड्रेन लेआऊटचे काम मंजूर नुसारच करण्यांत यावे.
- २) या कामास येणारा खर्च आपणास/ आपले अशिलास स्वतः करावा लागणार असून, सदर खर्च भविष्यात महानगरपालिकेस देय राहणार नाही.
- ३) सदर गटार / नाला इत्यादी बांधण्यासाठी स्वतःच्या भूखंडाचा वापर करावा व आपल्या भूखंडातून सदर गटार काढून महानगरपालिकेस मुख्य / नाल्यास जोडण्यांत यावे, अन्यथा इतर भूखंडधारकांनी हरकत घेतल्यास सर्वस्वी जबाबदारी आपली राहिल.
- ४) भविष्यात इतर भूखंडातून पावसाठी पाण्याचा / मैलापाण्याचा निचरा करण्याचे दृष्टीकोनातून गटार/मलवाहिनी बांधावयाचे / टाकावयाची झाल्यास सदर भूखंडातून गटार / मलवाहिनी बांधणेकरीता / टाकणेकरीता आपणास / आपले अशिलास तसेच सदनिकाधारकास कोणतीही हरकत घेता येणार नाही.

SWD Remark

- ५) स्टॉर्म वॉटर ड्रेनेज चे व नाल्याचे काम इमारतीच्या प्रथम वापर परवान्यापूर्वी करून पावसाळी पाण्याचा निचरा होणेकरिता स्टॉर्म वॉटर ड्रेनेजचे आऊटलेट पनवेल महानगरपालिकेच्या मुख्य गटारास / नाल्यास जोडण्यांत यावे.
- ६) स्टॉर्म वॉटर ड्रेनेजचे काम पूर्ण झाल्यावर इमारतीच्या वापर परवान्यापूर्वी स्टॉर्म वॉटर ड्रेनेजच्या पूर्णत्वाचा दाखला महानगरपालिकेच्या संबंधित विभागाकडून घेणे बंधनकारक राहिल.
- ७) सदर मंजूर स्टॉर्म वॉटर ड्रेनेज लेआऊट नकाशामध्ये भविष्यामध्ये कोणताही बदल करावयाचा झाल्यास त्यास पुन्हा मान्यता घेणे बंधनकारक राहिल.
- ८) आजुबाजुच्या भूखंडामधील स्टॉर्म वॉटर ड्रेनेजचे पाणी आपले भूखंडामधील स्टॉर्म वॉटर ड्रेनेजत मध्ये घेणे बंधनकारक राहिल. त्यास आपण/आपले अशिल/सदनिका धारक यांना कोणतीही हरकत घेता येणार नाही.
- ९) भूखंडामधील स्टॉर्म वॉटर ड्रेनेजचे आऊटलेट स्टॉर्म वॉटर ड्रेनेज लेआऊट नकाशामध्ये दाखविल्याप्रमाणे बांधण्यांत यावे.
- १०) वेळोवेळी होणारे बदल / सुधारणेनुसार सदर परवानगी बदल करण्याचा अधिकार निम्न स्वाक्षरीकार यांनी राखून ठेवला आहे.
- ११) पोडीयम वरील पावसाचे पाणी ठिकठिकाणी पुरेशे पाईपचे सहाय्याने स्टॉर्म वॉटर ड्रेनेजला जोडणे बंधनकारक राहिल. त्यासाठी पोडीयम खाली स्टील लेव्हल/प्राऊंड लेव्हलला स्टॉर्म वॉटर ड्रेनेज बांधून ते नजीकच्या स्टॉर्म वॉटर ड्रेनेजला जोडणे बंधनकारक राहिल. सदरचे काम स्टॉर्म वॉटर ड्रेनेज हे स्लॅबने बंदिस्त करणे ऐवजी लोखंडी जाळीने कव्हर करण्यांत यावे.
- १२) नियोजन प्राधिकरणाने दिलेल्या बांधकाम परवानगीमधील सर्व शर्ती/अटी अर्जदार यांना बंधनकारक राहतील.
- १३) शासनाचे पर्यावरण विभागाकडील संबंधित परिपत्रकाचे, शासन नियमांचे सर्व शर्ती/अटी अर्जदार

- यांना बंधनकारक राहतील. त्याचे उल्लंघन होणार नाही याची अर्जदार यांनी दक्षता घेणेत यावी.
- १४) सदर जागेबाबत कोणत्याही न्यायालयात/प्राधिकरणासमोर कोणत्याही प्रकारचा दावा/वाद चालू असल्यास त्याची जबाबदारी अर्जदार/जमीन मालक यांची राहिल.
- १५) अर्जदार यांनी सादर केलेली माहिती/कागदपत्रे खोटी अथवा दिशाभूल करणारी असल्यास सदर परवानगी रद्द समजण्यात येईल.

(संजय जगताप)
शहर अभियंता
पनवेल महानगरपालिका

ENERGY SAVING MEASURES

COMMON AREA LIGHTING DETAILS

Description	CL (kW)	MD (KW)	Full load hrs	Daily Consumption (Kw-h)	Annual Diversity	Annual Consumption (Kw-h) per annum	% savings	KWh Saved per Annum	Savings due to
A) Residential areas									
Flats									
Lighting	370.25	148	5	740.5	0.8	216226	30	64867.8	Use of T-5 Fittings (28 w) and Electronic ballasts instead of Fluoroscent Light fittings (40w) and copper ballasts.
A/C and other Domestic Equipments	2742	1097	3	3290.4	0.4	480398.4	10	48039.84	User to be recommended to use BEE FIVE star certified appiance and Airconditioners.
Hot water Gyser	1830	732	2	1464	0.4	213744	10	21374.4	User to be recommended to use BEE FIVE star certified appiance
B) Common Areas									
Water Pumps	47.5	33	12	399	0.8	116508	15	17476.2	Use of BEE Certified Motors
FFTG	15	15	0.1	1.5	0.4	219	0	0	
Lifts	26.4	18	3	55.44	0.6	12141.36	20	2428.272	Use of Group controls and Variable speed drives.
Lighting of Lobby & common area residential etc	60	42	10	420	0.8	122640	50	61320	Use of LED fittings (18 w) and Electronic ballasts instead of Fluoroscent Light fittings (40w) and copper ballasts.
street Light	20	16	10	160	0.8	46720	30	14016	Daylight based controls + LED light fitting to be consider instead of convectional fittings
landscape Lighting	30	21	10	210	0.8	61320	30	18396	Daylight based controls + LED light fitting to be consider instead of convectional fittings
parking/services area	33	26	10	264	0.9	86724	50	43362	Use of LED fittings (18 w) and Electronic ballasts instead of Fluoroscent Light fittings (40w) and copper ballasts.
Lighting of Staircase sale building	11.2	10	10	100.8	0.8	29433.6	50	14716.8	Use of LED fittings (18 w) and Electronic ballasts instead of Fluoroscent Light fittings (40w) and copper ballasts.
Miscellaneous power	298	179	3	536.4	0.5	97893	15	14683.95	Use of EFF-1 motors for fans & pumps.
Car charging point	428	300	3	898.8	0.2	65612.4	10	6561.24	User to be recommended to use BEE FIVE star certified appiance
Pressurazation	354	212	0.1	21.24	0.3	2325.78	15	348.867	Use of CO sensors and VFD Fans
TOTAL						1736151.7		350126.469	
% Savings Trough Conventional Energy saving systems Systems- A								20.2	

ENERGY SAVING MEASURES

Solar PV cells -B	87782.50	150Solar PV panels Installed on residential building Terrace (48.10kwp) To feed the common area lighting of the building.
Total Savings through Renewable Energy	87782.5	
% Savings through Renewable energy	5.06	Renewable shall be 5.0% of the total energy saving.
TOTAL ENERGY SANVING (A+B)	437908.97	
% Savings TOTAL Energy saving systems Systems- A+B	25.2	

Building No.	Total Terrace area	Terrace area required	Total Panels proposed	Total terrace are required for panels	Total terrace are required with side circulation	solar panel	kwph/day	kwh/annu m
	sq mt	in sq.mt	(2.0 sqmt / panel)		(3.0 sqmt / panel)	0.325kw- /panel		
WING-A	400	75	25	50	75	8		
WING-B	400	75	25	50	75	8		
WING-C	400	75	25	50	75	8		
WING-D	400	75	25	50	75	8		
WING-E	400	75	25	50	75	8		
WING-F	400	75	25	50	75	8		
Total	2400	450.00	150.00	300	450	48.10	240.5	87782.5

As per MNRE guidelines 5kwh/unit of electricity per day is consider

ENERGY SAVING MEASURES



BLDG	SOLAR PANEL
A-WING	25 NOS
B-WING	25 NOS
C-WING	25 NOS
D-WING	25 NOS
E-WING	25 NOS
F-WING	25 NOS
TOTAL	150 NOS

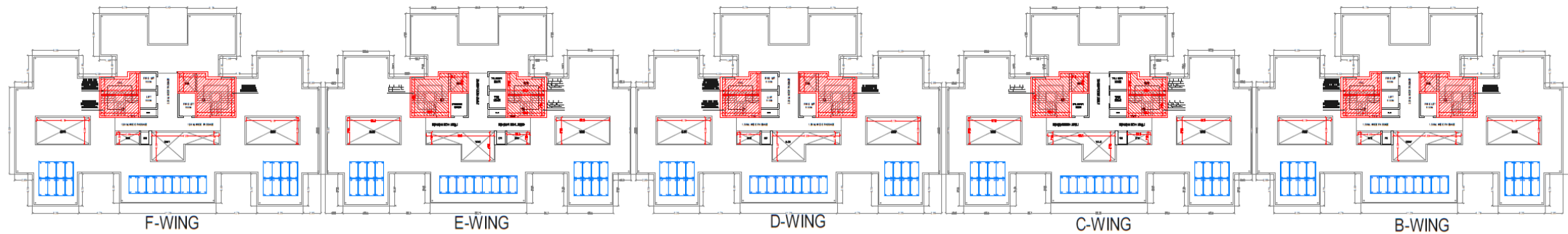
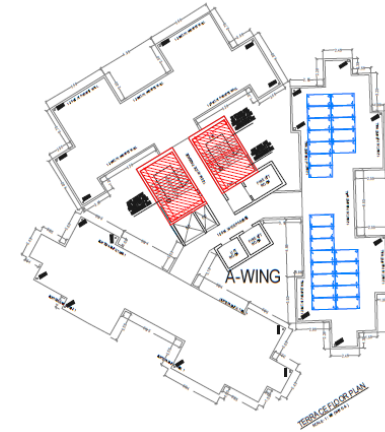

TERRACE PLAN
(WING A,B,C,D,E & F)

SOLAR PANEL LOCATION

STP LOCATION AND SEWERAGE NETWORK

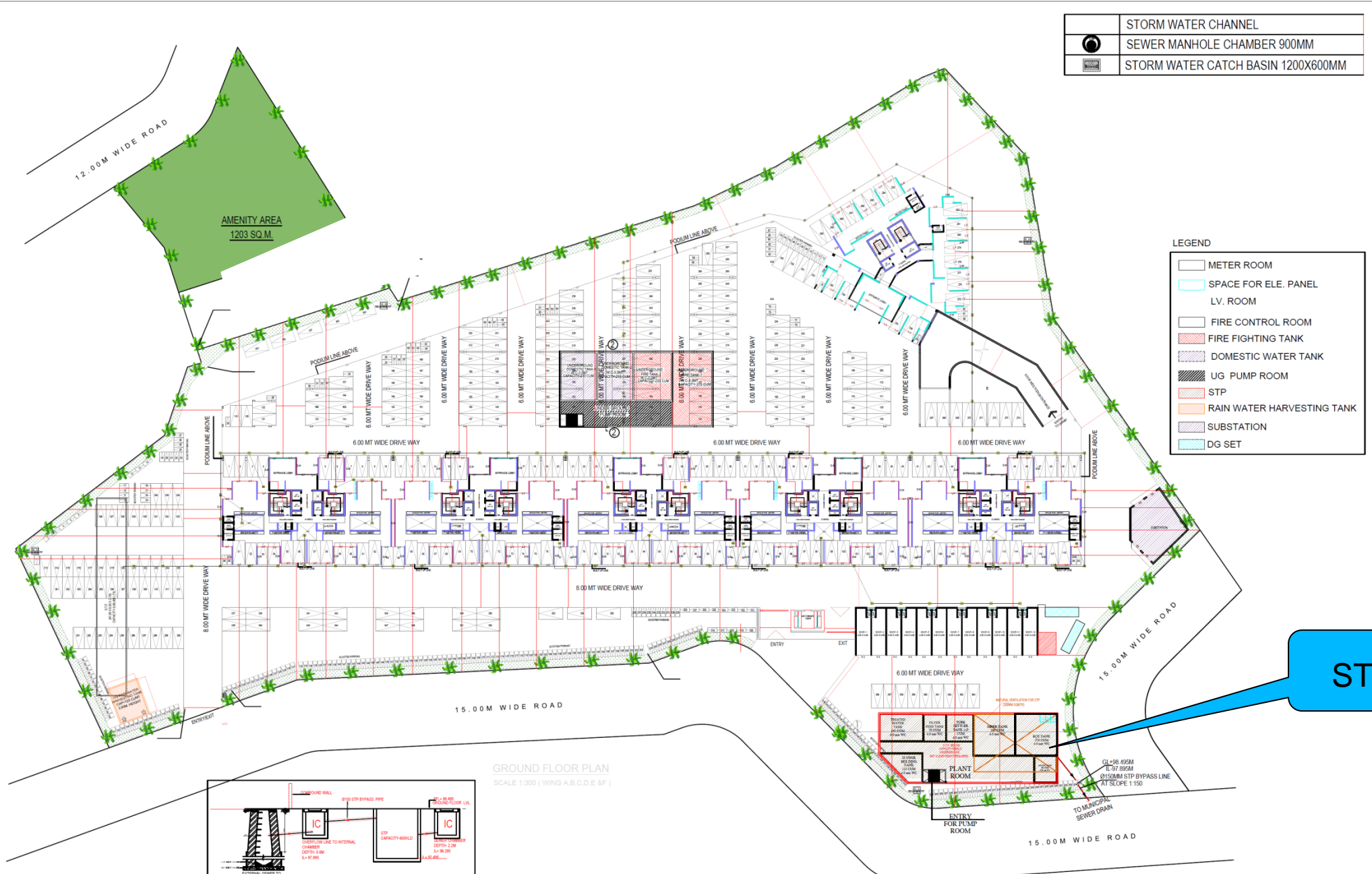

	STORM WATER CHANNEL
	SEWER MANHOLE CHAMBER 900MM
	STORM WATER CATCH BASIN 1200X600MM

LEGEND

	METER ROOM
	SPACE FOR ELE. PANEL
	LV. ROOM
	FIRE CONTROL ROOM
	FIRE FIGHTING TANK
	DOMESTIC WATER TANK
	UG PUMP ROOM
	STP
	RAIN WATER HARVESTING TANK
	SUBSTATION
	DG SET

GROUND FLOOR PLAN
SCALE 1:300 (WING A,B,C,D,E & F)

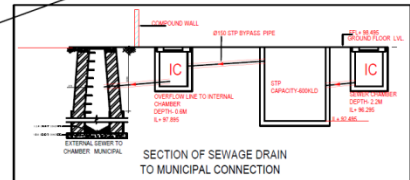

SEWER DRAIN LAYOUT

STP -PROCESS & SCHEMATIC DIAGRAM

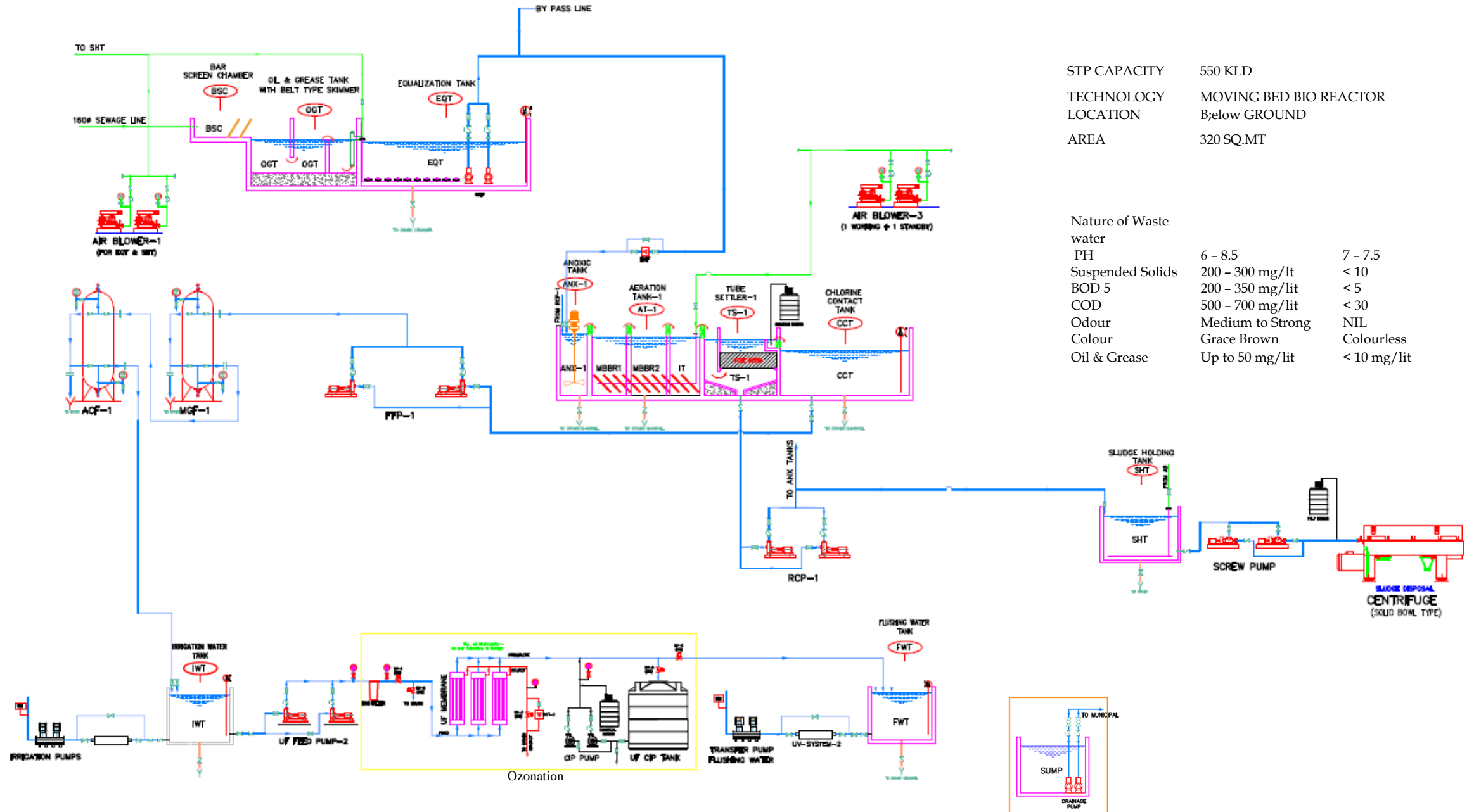

STP CAPACITY 550 KLD
 TECHNOLOGY MOVING BED BIO REACTOR
 LOCATION Below GROUND
 AREA 320 SQ.MT

Nature of Waste water

PH	6 - 8.5	7 - 7.5
Suspended Solids	200 - 300 mg/lit	< 10
BOD 5	200 - 350 mg/lit	< 5
COD	500 - 700 mg/lit	< 30
Odour	Medium to Strong	NIL
Colour	Grace Brown	Colourless
Oil & Grease	Up to 50 mg/lit	< 10 mg/lit

Ozonation

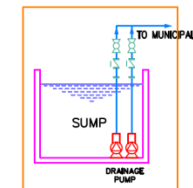

STP PLAN & SECTION

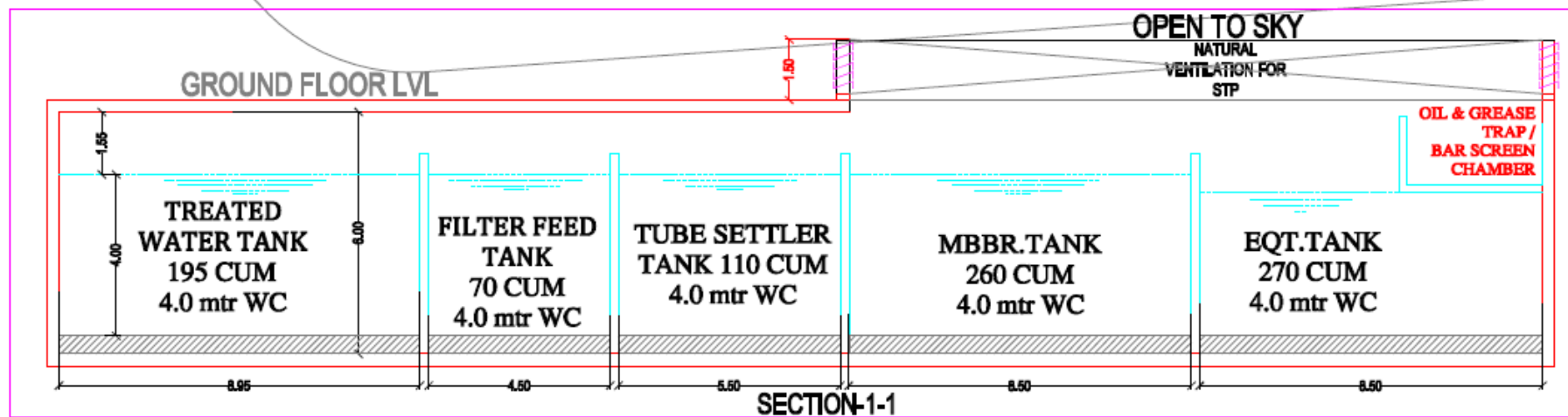
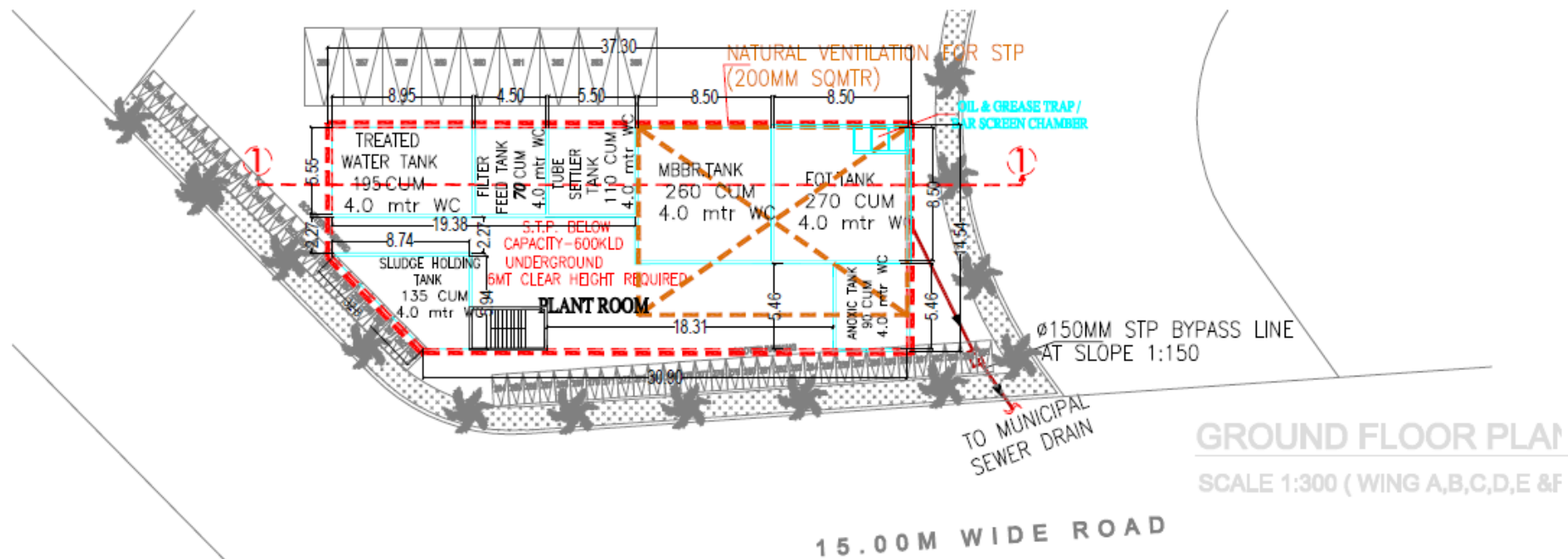

LANDSCAPE PLAN



GROUND FLOOR PLAN
SCALE 1:250 (WING A,B,C,D,E & F)

Description of Area	Details
Required RG	2159.20 sq.mt
Provided RG	3670.00 sq.m
R.G on Ground	886.42 sq.m
R.G on Podium	2783.58 sq.m
Total Trees proposed	435 No's

ENVIRONMENT MANAGEMENT PLAN

#	Particulars	Capital Cost (Lacs)	O & M Cost (Lacs/ Annum)
1.	Sewage Treatment Plant	95.00	10.50
2.	RWH System	10.00	1.00
3.	Environmental Monitoring	--	1.75
4.	Solid Waste Management	14.00	3.75
5.	Solar Energy System	50.00	3.50
6.	Low Flow water fixer	8.0	0.50
7.	Landscaping	25.00	4.00
	Total Cost	202.00	25.00

Short term and long term arrangement for the EMP

- ❖ After occupancy, Co-Op societies will be formed.
- ❖ The EMP measures shall be taken care by the developers for first three years.
- ❖ Afterwards, STP shall be handed over to society/ federation
- ❖ Funds for recurring cost on EMP shall be generated from the tenants of the society by specifically mentioning in the sale agreement.

Social aspect need to be highlighted

1. Employment strategy would provide for preferential employment of local labour.
2. Generating opportunities for other business like workshops, marketing, repair and maintenance tasks etc.
3. Preference locals to milk supply, vegetables etc.

पब्लिक नोटीस

तमाम जनतेस व पर्यावरणीय गट यांस कळविण्यात येते की, महाराष्ट्र सरकार पर्यावरण विभाग रुम नं. २१७, दुसरा मजला, मंत्रालय विस्तारित, मुंबई-४०० ०३२ यानी दि. २१/१२/२०२१ च्या पत्र क्र. SAI/MH/MIS/213444/2021 व EC Indentification No. EC21BO38MH147612 द्वारे महावीर सुपरस्ट्रक्चर्स प्रा.लि. यांना 'महावीर एक्झोटिक', या रहिवाशी व वाणिज्य प्रकल्पासाठी, जो मौजे, रोहिंगण, ता. पनवेल जि. रायगड येथील सव्हे नं./हिस्सा नं. १९/१, २०/०, २४/अ/८/ब यावर स्थापित होत आहे. यासाठी पर्यावरण विषयक परवानगी दिलेली आहे. सदर परवानगी पत्राची प्रत महाराष्ट्र शासन, पर्यावरण विभाग मंत्रालय व महाराष्ट्र राज्य प्रदूषण निमंत्रण मंडळाकडे उपलब्ध आहे. त्याचप्रमाणे <https://ec.maharashtra.gov.in> या वन व पर्यावरण मंत्रालयाच्या वेबसाईटवर उपलब्ध आहे.

PUBLIC NOTICE

All the concerned persons including bonafied residents, environmental groups and others are hereby informed that the Department of Environment, Government of Maharashtra has accorded Environmental Clearance for MAHAAVIR SUPERSTRUCTURES PVT. LTD on their Proposed Building and Construction project at Survey No. 19/1, 20/0 & 24/A/8/B, Village – Rohinan, Taluka – Panvel, District – Raigad under EC Identification No. EC21B038MH147612 and EC Letter No. SIA/MH/MIS/213444/2021 dated 21/12/2021.

The copy of clearance letter is available with the
<https://www.parivesh.nic.in>



Government of India
Ministry of Environment, Forest and Climate Change
(Issued by the State Environment Impact Assessment
Authority(SEIAA), Maharashtra)

To,

The Director
MAHAAVIR SUPERSTRUCTURES PVT LTD
Office no 1003-1009, Wing A, 10 Floor, Mahaavir Icon, Sector 15, CBD
Belapur, Navimumbai -400614

Subject: Grant of Environmental Clearance (EC) to the proposed Project Activity
under the provision of EIA Notification 2006-regarding

Sir/Madam,

This is in reference to your application for Environmental Clearance (EC)
in respect of project submitted to the SEIAA vide proposal number
SIA/MH/MIS/213444/2021 dated 29 May 2021. The particulars of the environmental
clearance granted to the project are as below.

1. EC Identification No.	EC21B038MH147612
2. File No.	SIA/MH/MIS/213444/2021
3. Project Type	New
4. Category	B2
5. Project/Activity including Schedule No.	8(a) Building and Construction projects
6. Name of Project	MAHAAVIR SUPERSTRUCTURES PVT. LTD
7. Name of Company/Organization	MAHAAVIR SUPERSTRUCTURES PVT LTD
8. Location of Project	Maharashtra
9. TOR Date	N/A

The project details along with terms and conditions are appended herewith from page
no 2 onwards.

Date: 21/12/2021

(e-signed)
Manisha Patankar Mhaikar
Member Secretary
SEIAA - (Maharashtra)

*Note: A valid environmental clearance shall be one that has EC identification
number & E-Sign generated from PARIVESH. Please quote identification
number in all future correspondence.*

This is a computer generated cover page.

PARIVESH

(Pro-Active and Responsive Facilitation by Interactive,
and Virtuous Environmental Single-Window Hub)



STATE LEVEL ENVIRONMENT IMPACT ASSESSMENT AUTHORITY

No. SIA/MH/MIS/213444/2021
Environment & Climate
Change Department
Room No. 217, 2nd Floor,
Mantralaya, Mumbai- 400032.

To
M/s Mahaavir Superstructures Private Limited.,
Survey No. 19 Hissa Nos. 1, Survey No. 20,
Survey No. 24 Hissa No. A/8/B & Survey No.25,
Hissa No.1 Village Rohinjan, Taluka Panvel, District Raigad

Subject : Environmental Clearance for proposed Residential cum commercial project at Plot bearing Survey No. 19 Hissa Nos. 1, Survey No. 20, Survey No. 24 Hissa No. A/8/B and Survey No.25 Hissa No.1 of Village Rohinjan Taluka Panvel District Raigad by M/s Mahaavir Superstructures Private Limited.

Reference : Application no. SIA/MH/MIS/213444/2021

This has reference to your communication on the above mentioned subject. The proposal was considered by the SEAC-2 in its 154th meeting under screening category 8 (a) B2 as per EIA Notification, 2006 and recommend to SEIAA. Proposal then considered in 233rd (Day-2) meeting of State Level Environment Impact Assessment Authority (SEIAA).

2. Brief Information of the project submitted by you is as below:-

Sr. No.	Description	Details
1	Plot Area (sq. m)	24055.00
2	FSI Area (sq. m)	64948.76
3	Non-FSI Area (sq. m)	27612.24
4	Proposed built-up area (FSI + FSI) (sq. m)	92561.00
5	Building Configuration	05 Bldg: G + 3 P + 19 01 Bldg: G + 3 P + 26; Clubhouse: G+1
6	No. of Tenements & shops	Tenements:968, Shops: 12
7	Total population	Residential: 4455
8	Total Water Requirement CMD	647 CMD
9	Sewage Generation CMD	542 CMD
10	STP Capacity & Technology	660 CMD (MBBR Technology)

11	STP Location	below Ground						
12	Total Solid waste Quantities	Wet Waste: 0.81 TPD Dry Waste: 1.23 TPD Total: 2.04 TPD Disposal: OWC for wet waste						
13	R.G Area in sq.m	<table border="1"> <tr> <td>Provided RG</td> <td>3670.00 sq.m</td> </tr> <tr> <td>R.G on Ground</td> <td>886.42 sq.m</td> </tr> <tr> <td>R.G on Podium</td> <td>2783.58 sq.m</td> </tr> </table>	Provided RG	3670.00 sq.m	R.G on Ground	886.42 sq.m	R.G on Podium	2783.58 sq.m
Provided RG	3670.00 sq.m							
R.G on Ground	886.42 sq.m							
R.G on Podium	2783.58 sq.m							
14	Power requirement	3116 KVA						
15	Energy Efficiency	Total Energy Savings: 20.9 % By Solar Energy: 5.08 %						
16	D.G. set capacity	2 x 500 KVA,						
17	Parking 4W & 2W	4W: 783 Nos; 2 W: 365						
18	Rain water harvesting Scheme	125 cum RWH Tank;						
19	Project Cost in (Cr)	164.00 Cr						
20	EMP Cost	Capital Cost – 202.00 Lakhs O & M Cost – 25.00 Lakhs						
21	CER Details	1.5 % of Project cost						
22	U.G tank details:	As per NBC norms						

3. Proposed construction project is a new project. Proposal has been considered by SEIAA in its 233rd (Day-2) meeting and decided to accord Environment Clearance to the said project under the provisions of Environment Impact Assessment Notification, 2006 subject to implantation of following terms and conditions-

Specific Conditions:

A. SEAC Conditions-

1. PP to submit IOD/IOA/Concession Document/Plan Approval or any other form of documents as applicable clarifying its conformity with local planning rules and provisions thereunder as per the circular dated 30.01.2014 issued by the Environment Department, Govt. of Maharashtra.
2. PP to obtain following NOCs:
 - a) Water Supply, b) Sewer NOC, c) SWM NOC, d) Storm Water Drain remarks,
 - e) Tree NOC.
3. PP to reduce the discharge of treated sewage to 35%. PP to submit NOC from concern authority for use of excess treated water in nearby Garden reservation/ Construction.

4. PP to provide Low Flow Devices (LFD) & Sensors as water conservation measures in operation phase; PP to provide portable STP for workers in construction phase & accordingly revise construction & operation phase EMP.
5. PP to revise Disaster Management Plan (DMP) with monetary provision & include the cost of DMP in EMP.
6. PP to submit revise energy calculation with terrace floor plan for installing solar panel.
7. Planning authority to ensure sewer lines & storm water drain network before issuing Occupation Certificate.
8. PP to remove use of treated water shown for vehicle washing in water balance chart & accordingly revise water balance.

B. SEIAA Conditions-

1. PP to strictly adhere to all the conditions mentioned in Maharashtra (Urban Areas) Protection and Preservation of Trees Act, 1975 as amended during the validity of Environment Clearance.
2. PP to keep open space unpaved so as to ensure permeability of water. However, whenever paving is deemed necessary, PP to provide grass pavers of suitable types & strength to increase the water permeable area as well as to allow effective fire tender movement.
3. PP to achieve at least 5% of total energy requirement from solar/other renewable sources.
4. PP Shall comply with Standard EC conditions mentioned in the Office Memorandum issued by MoEF& CC vide F.No.22-34/2018-IA.III dt.04.01.2019.
5. SEIAA after deliberation decided to grant EC for – FSI- 64948.76 m², Non-FSI- 27612.24 m², Total BUA-92561.00 m². (Plan approval-PMC/TP/Rohinjan/190, dated-17.09.2021).

General Conditions:

a) Construction Phase :-

- I. The solid waste generated should be properly collected and segregated. Dry/inert solid waste should be disposed of to the approved sites for land filling after recovering recyclable material.
- II. Disposal of muck, Construction spoils, including bituminous material during construction phase should not create any adverse effect on the neighbouring communities and be disposed taking the necessary precautions for general safety and health aspects of people, only in the approved sites with the approval of competent authority.
- III. Any hazardous waste generated during construction phase should be disposed of as per applicable rules and norms with necessary approvals of the Maharashtra Pollution Control Board.
- IV. Adequate drinking water and sanitary facilities should be provided for construction workers at the site. Provision should be made for mobile toilets. The safe disposal of wastewater and solid wastes generated during the construction phase should be ensured.
- V. Arrangement shall be made that waste water and storm water do not get mixed.

- VI. Water demand during construction should be reduced by use of pre-mixed concrete, curing agents and other best practices.
- VII. The ground water level and its quality should be monitored regularly in consultation with Ground Water Authority.
- VIII. Permission to draw ground water for construction of basement if any shall be obtained from the competent Authority prior to construction/operation of the project.
- IX. Fixtures for showers, toilet flushing and drinking should be of low flow either by use of aerators or pressure reducing devices or sensor based control.
- X. The Energy Conservation Building code shall be strictly adhered to.
- XI. All the topsoil excavated during construction activities should be stored for use in horticulture / landscape development within the project site.
- XII. Additional soil for levelling of the proposed site shall be generated within the sites (to the extent possible) so that natural drainage system of the area is protected and improved.
- XIII. Soil and ground water samples will be tested to ascertain that there is no threat to ground water quality by leaching of heavy metals and other toxic contaminants.
- XIV. PP to strictly adhere to all the conditions mentioned in Maharashtra (Urban Areas) Protection and Preservation of Trees Act, 1975 as amended during the validity of Environment Clearance.
- XV. The diesel generator sets to be used during construction phase should be low sulphur diesel type and should conform to Environments (Protection) Rules prescribed for air and noise emission standards.
- XVI. PP to strictly adhere to all the conditions mentioned in Maharashtra (Urban Areas) Protection and Preservation of Trees Act, 1975 as amended during the validity of Environment Clearance.
- XVII. Vehicles hired for transportation of Raw material shall strictly comply the emission norms prescribed by Ministry of Road Transport & Highways Department. The vehicle shall be adequately covered to avoid spillage/leakages.
- XVIII. Ambient noise levels should conform to residential standards both during day and night. Incremental pollution loads on the ambient air and noise quality should be closely monitored during construction phase. Adequate measures should be made to reduce ambient air and noise level during construction phase, so as to conform to the stipulated standards by CPCB/MPCB.
- XIX. Diesel power generating sets proposed as source of backup power for elevators and common area illumination during construction phase should be of enclosed type and conform to rules made under the Environment (Protection) Act, 1986. The height of stack of DG sets should be equal to the height needed for the combined capacity of all proposed DG sets. Use low sulphur diesel is preferred. The location of the DG sets may be decided with in consultation with Maharashtra Pollution Control Board.
- XX. Regular supervision of the above and other measures for monitoring should be in place all through the construction phase, so as to avoid disturbance to the surroundings by a separate environment cell /designated person.

B) Operation phase:-

- I. a) The solid waste generated should be properly collected and segregated. b) Wet waste should be treated by Organic Waste Converter and treated waste (manure) should be utilized in the existing premises for gardening. And, no wet garbage will be disposed outside the premises. c) Dry/inert solid waste should be disposed of to the approved sites for land filling after recovering recyclable material.
- II. E-waste shall be disposed through Authorized vendor as per E-waste (Management and Handling) Rules, 2016.
- III. a) The installation of the Sewage Treatment Plant (STP) should be certified by an independent expert and a report in this regard should be submitted to the MPCB and Environment department before the project is commissioned for operation. Treated effluent emanating from STP shall be recycled/ reused to the maximum extent possible. Treatment of 100% grey water by decentralized treatment should be done. Necessary measures should be made to mitigate the odour problem from STP. b) PP to give 100 % treatment to sewage /Liquid waste and explore the possibility to recycle at least 50 % of water, Local authority should ensure this.
- IV. Project proponent shall ensure completion of STP, MSW disposal facility, green belt development prior to occupation of the buildings. As agreed during the SEIAA meeting, PP to explore possibility of utilizing excess treated water in the adjacent area for gardening before discharging it into sewer line No physical occupation or allotment will be given unless all above said environmental infrastructure is installed and made functional including water requirement.
- V. The Occupancy Certificate shall be issued by the Local Planning Authority to the project only after ensuring sustained availability of drinking water, connectivity of sewer line to the project site and proper disposal of treated water as per environmental norms.
- VI. Traffic congestion near the entry and exit points from the roads adjoining the proposed project site must be avoided. Parking should be fully internalized and no public space should be utilized.
- VII. PP to provide adequate electric charging points for electric vehicles (EVs).
- VIII. Green Belt Development shall be carried out considering CPCB guidelines including selection of plant species and in consultation with the local DFO/ Agriculture Dept.
- IX. A separate environment management cell with qualified staff shall be set up for implementation of the stipulated environmental safeguards.
- X. Separate funds shall be allocated for implementation of environmental protection measures/EMP along with item-wise breaks-up. These cost shall be included as part of the project cost. The funds earmarked for the environment protection measures shall not be diverted for other purposes.
- XI. The project management shall advertise at least in two local newspapers widely circulated in the region around the project, one of which shall be in the Marathi language of the local concerned within seven days of issue of this letter, informing that the project has been accorded environmental clearance and copies of clearance letter are available with the Maharashtra Pollution Control Board and may also be seen at Website at <http://parivesh.nic.in>
- XII. Project management should submit half yearly compliance reports in respect of the

stipulated prior environment clearance terms and conditions in hard & soft copies to the MPCB & this department, on 1st June & 1st December of each calendar year.

- XIII. A copy of the clearance letter shall be sent by proponent to the concerned Municipal Corporation and the local NGO, if any, from whom suggestions/representations, if any, were received while processing the proposal. The clearance letter shall also be put on the website of the Company by the proponent.
- XIV. The proponent shall upload the status of compliance of the stipulated EC conditions, including results of monitored data on their website and shall update the same periodically. It shall simultaneously be sent to the Regional Office of MoEF, the respective Zonal Office of CPCB and the SPCB. The criteria pollutant levels namely; SPM, RSPM, SO₂, NO_x (ambient levels as well as stack emissions) or critical sector parameters, indicated for the project shall be monitored and displayed at a convenient location near the main gate of the company in the public domain.

C) General EC Conditions:-

- I. PP has to strictly abide by the conditions stipulated by SEAC & SEIAA.
- II. If applicable "Consent for Establishment" shall be obtained from Maharashtra Pollution Control Board under Air and Water Act and a copy shall be submitted to the Environment department before start of any construction work at the site.
- III. Under the provisions of Environment (Protection) Act, 1986, legal action shall be initiated against the project proponent if it was found that construction of the project has been started without obtaining environmental clearance.
- IV. The project proponent shall also submit six monthly reports on the status of compliance of the stipulated EC conditions including results of monitored data (both in hard copies as well as by e-mail) to the respective Regional Office of MoEF, the respective Zonal Office of CPCB and the SPCB.
- V. The environmental statement for each financial year ending 31st March in Form-V as is mandated to be submitted by the project proponent to the concerned State Pollution Control Board as prescribed under the Environment (Protection) Rules, 1986, as amended subsequently, shall also be put on the website of the company along with the status of compliance of EC conditions and shall also be sent to the respective Regional Offices of MoEF by e-mail.
- VI. No further Expansion or modifications, other than mentioned in the EIA Notification, 2006 and its amendments, shall be carried out without prior approval of the SEIAA. In case of deviations or alterations in the project proposal from those submitted to SEIAA for clearance, a fresh reference shall be made to the SEIAA as applicable to assess the adequacy of conditions imposed and to add additional environmental protection measures required, if any.
- VII. This environmental clearance is issued subject to obtaining NOC from Forestry & Wild life angle including clearance from the standing committee of the National Board for Wild life as if applicable & this environment clearance does not necessarily implies that Forestry & Wild life clearance granted to the project which will be considered separately on merit.

4. The environmental clearance is being issued without prejudice to the action initiated under EP Act or any court case pending in the court of law and it does not mean that project proponent

has not violated any environmental laws in the past and whatever decision under EP Act or of the Hon'ble court will be binding on the project proponent. Hence this clearance does not give immunity to the project proponent in the case filed against him, if any or action initiated under EP Act.

5. This Environment Clearance is issued purely from an environment point of view without prejudice to any court cases and all other applicable permissions/ NOCs shall be obtained before starting proposed work at site.

6. In case of submission of false document and non-compliance of stipulated conditions, Authority/ Environment Department will revoke or suspend the Environment clearance without any intimation and initiate appropriate legal action under Environmental Protection Act, 1986.

7. Validity of Environment Clearance: The environmental clearance accorded shall be valid as per EIA Notification, 2006, amended from time to time.

8. The above stipulations would be enforced among others under the Water (Prevention and Control of Pollution) Act, 1974, the Air (Prevention and Control of Pollution) Act, 1981, the Environment (Protection) Act, 1986 and rules there under, Hazardous Wastes (Management and Handling) Rules, 1989 and its amendments, the public Liability Insurance Act, 1991 and its amendments.

9. Any appeal against this Environment clearance shall lie with the National Green Tribunal (Western Zone Bench, Pune), New Administrative Building, 1st Floor, D-Wing, Opposite Council Hall, Pune, if preferred, within 30 days as prescribed under Section 16 of the National Green Tribunal Act, 2010.

Manisha Patankar-Mhaiskar
(Member Secretary, SEIAA)
14/12/2021

Copy to:

1. Chairman, SEIAA, Mumbai.
2. Secretary, MoEF & CC, IA- Division MOEF & CC
3. Member Secretary, Maharashtra Pollution Control Board, Mumbai.
4. Regional Office MoEF & CC, Nagpur
5. District Collector, Raigad .
6. Commissioner, Panvel Municipal Corporation
7. Regional Officer, Maharashtra Pollution Control Board, Raigad.

MAHARASHTRA POLLUTION CONTROL BOARD

Tel: 022-27576034
Fax: 022- 27576034
Website: <http://mpcb.gov.in>
Email: sroraigad1@mpcb.gov.in



Maharashtra Pollution
Control Board, Raigad
Bhavan, 6th floor, Sector -
11, C.B.D Belapur, Navi
Mumbai.

GREEN/M.S.I (G37)
No:- Format1.0/SRO/UAN
No.0000138694/CE/2206001005

Date: 20/06/2022

To,
M/s. Mahaavir Superstructures Pvt. Ltd.
Survey No. 19/1, Survey No. 20, Survey No. 24/A/8B,
Village: Rohinjan, Taluka: Panvel; District: Raigad.



Your Service is Our Duty

Sub: Consent to Establish under Green Category

Ref: Your application No. MPCB-CONSENT-0000138694, Dated 09.05.2021.

Your application No.MPCB-CONSENT-0000138694 Dated 09.05.2022

For: grant of Consent to Establish under Section 25 of the Water (Prevention & Control of Pollution) Act, 1974 & under Section 21 of the Air (Prevention & Control of Pollution) Act, 1981 and Authorization under Rule 6 of the Hazardous & Other Wastes (Management & Transboundary Movement) Rules 2016 is considered and the consent is hereby granted subject to the following terms and conditions and as detailed in the schedule I, II, III & IV annexed to this order:

- The consent to establish is granted for a period up to commissioning of the unit or up to 5 year whichever is earlier.**
- The capital investment of the project is Rs.8.8523 Crs. (As per C.A Certificate submitted by industry)**
- Consent is valid for the manufacture of:**

Sr No	Product	Maximum Quantity	UOM
Products			
1	Ready Mix Concrete (Captive Purpose Only)	1500	MT/M

- Conditions under Water (P&CP), 1974 Act for discharge of effluent:**

Sr No	Description	Permitted (in CMD)	Standards to	Disposal Path
1.	Trade effluent	0.0	As per Schedule-I	Not Applicable
2.	Domestic effluent	1.0	As per Schedule-I	

- Conditions under Air (P& CP) Act, 1981 for air emissions:**

Sr No.	Stack No.	Description of stack / source	Number of Stack	Standards to be achieved
1	1	DG Set	1	As per Schedule -II

6. **Non-Hazardous Wastes:**

Sr No	Type of Waste	Quantity	UoM	Treatment	Disposal
NA					

Solid waste from transit mixture washing, muck (debris/sludge) generated from RMC shall either be reused through recovery unit/ Reclaiming system OR disposed off at a designated approved site by local body, for debris / construction waste.

7. **Conditions under Hazardous & Other Wastes (M & T M) Rules 2016 for treatment and disposal of hazardous waste:**

Sr No	Category No./ Type	Quantity	UoM	Treatment	Disposal
NA					

8. The consent is issued subject to direction issued by CPCB under section 18(1) (b) of Water (Prevention and Control of Pollution) Act, 1974, regarding classification of Industries dated 07th March 2016.
9. Operation of RMC plant shall be in daytime only. The Day time is reckoned in between 6 a.m. and 6 p.m. i.e. from sun rise to sunset.
10. The Board may make the standards stringent for the RMC/batching plants located within Corporation areas.
11. Captive plants shall carryout ambient air quality monitoring twice in a week for 24 hours.
12. The industry shall comply with the siting criteria as per RMC Noti?cation dtd 16.10.2016.
13. The Board reserves the right to review, amend, suspend, revoke etc. this consent and the same shall be binding on the industry.
14. The applicant shall make an application for consent to operate prior to commissioning before starting of production activity
15. This Consent is issued as per circular for Delegation of Power in respect of Consent Management dated 23/12/2020.
16. The industry shall obtain necessary permission from the Directorate of Industrial Safety and Health (DISH).

Received Consent fee of -

Sr.No	Amount(Rs.)	Transaction/DR.No.	Date	Transaction Type
1	25000.00	TXN2205003396	30/05/2022	Online Payment

Copy to:

1. Regional Officer, MPCB, Raigad
2. Chief Accounts Officer, MPCB, Sion, Mumbai

SCHEDULE-I

Terms & conditions for compliance of Water Pollution Control:

1. A] Generation - As per your application the treated effluent generation is Nil.
B] Treatment - NA
C] Disposal - NA
2. A] As per your application, you have provided Septic Tank followed by Soak pit for the treatment of 1.0 CMD of sewage.
B] The Applicant shall operate the sewage treatment system to treat the sewage so as to achieve the following standards.

Sr.No	Parameters	Standards (mg/l)	
1	Suspended Solids	Not to exceed	50
2	BOD 3 days 27°C	Not to exceed	30
3	COD	Not to exceed	100

- C] The treated sewage shall be recycled for secondary purposes to the maximum extent and remaining shall be discharged on land for gardening within premise after confirming above standards. In no case, sewage shall find its way for gardening / outside factory premises.
3. The Board reserves its rights to review plans, specifications or other data relating to plant setup for the treatment of waterworks for the purification there of & the system for the disposal of sewage or trade effluent or in connection with the grant of any consent conditions. The Applicant shall obtain prior consent of the Board to take steps to establish the unit or establish any treatment and disposal system or an extension or addition thereto.
4. The industry shall ensure replacement of pollution control system or its parts after expiry of its expected life as defined by manufacturer so as to ensure the compliance of standards and safety of the operation thereof.
5. The Applicant shall comply with the provisions of the Water (Prevention & Control of Pollution) Act, 1974 and as amended, by installing water meters and other provisions as contained in the said act:

Sr. No.	Purpose for water consumed	Water consumption quantity (CMD)
1.	Industrial Cooling, spraying in mine pits or boiler feed	0.00
2.	Domestic purpose	1.00
3.	Processing whereby water gets polluted & pollutants are easily biodegradable	114.00
4.	Processing whereby water gets polluted & pollutants are not easily biodegradable and are toxic	0.00
5.	Gardening	0

6. The Applicant shall provide Specific Water Pollution control system as per the conditions of EP Act, 1986 and rule made there under from time to time/ Environmental Clearance/ CREP guidelines.

SCHEDULE-II

Terms & conditions for compliance of Air Pollution Control:

1. As per your application, you have proposed to provide the Air pollution control (APC) system and also to erect following stack (s) to observe the following fuel pattern:

Stack No.	Source	APC System provided/proposed	Stack Height(in mtr)	Type of Fuel	Sulphur Content(in %)	Pollutant	Standard
1	DG Set	Acoustic Enclosure	5.00	HSD 31.25 --NA--	-	TPM	150 Mg/Nm ³
						Noise	-

2. The Applicant shall provide Specific Air Pollution control equipments as per the conditions of EP Act, 1986 and rule made there under from time to time/ Environmental Clearance / CREP guidelines.
3. The Applicant shall obtain necessary prior permission for providing additional control equipment with necessary specifications and operation thereof or alteration or replacement/alteration well before its life come to an end or erection of new pollution control equipment.
4. The Board reserves its rights to vary all or any of the condition in the consent, if due to any technological improvement or otherwise such variation (including the change of any control equipment, other in whole or in part is necessary).
5. The applicant shall install a comprehensive control system consisting of control equipments as is warranted with reference to generation of emission and operate and maintain the same continuously so as to achieve the level of pollutants to the following standards:



6. Control Equipment:

a. In-house measures :-

1. All material transfer points should be covered.
2. The dust containment system shall be provided incorporating either of the following:
 - i) Barricading all around the periphery of the plot boundary of height minimum 20 feet or 5 feet above free fall air emission area. Whichever is height with tin sheets same may extend above with netlon clothing whenever required.
 - ii) Water sprinkling/Chemical dust stabilizing agent spraying system along the periphery inside the premises of RMC.
 - iii) Tree plantation along the periphery inside boundary of the RMC premises having minimum width of 5 meters, on all sides. The foliage of the trees shall adequately cover area upto about 20m height.
3. Internal work area shall be, cement concreted/Asphalted
4. Daily cleaning / Removal of dust accumulation inside the plant (dry/wet) shall be carry out with industrial vacuum cleaner.
5. Two level type washing facility shall be provided at entry and exit points, for transit mixture vehicle.

b. Raw material storage & handling:-

1. Storage silos of cement & fly-ash shall be adequate capacity of dust Collection system such as multi - cyclone followed by bag house assembly.
2. Handling of Cement, sand, fly ash and aggregates shall be carried out with mechanical closed system only.
3. Manual operations shall be permitted only in a closed shed, equipped with dust control system at the loading point as well as roof top secondary dust control system.
4. All Conveyor belts of Sand, aggregate shall be covered with tin sheets and at points dust collection system to be installed to avoid secondary fugitive emissions.
5. Mixing section of cement, aggregate & sand shall be equipped with adequate capacity dust collection system, such as multi-cyclone followed by bag houses, so as to limit dust emissions.
6. Storage area of sand & aggregates shall be equipped with roof top water sprinkler system.
7. The production plant shall be interlocked with air pollution control system.
8. Alternative power supply system should cover both the production and Air Pollution control system.
9. Industry shall provide treatment facility industrial effluent.
10. Industry shall provide disposal facility for treated effluent.
11. Industry shall provide disposal facility for solid waste.
12. Industry shall provide proper exhaust system in the premises.

c. Ambient air quality as a distance of 10 mtr form source or the plant boundary whichever is nearer, shall meet the following standards

Particulate Matter PM 10	Not to Exceed	100 ug/m ³
Particulate Matter PM 2.5	Not to Exceed	60 ug/m ³

d. Solid waste treatment and disposal:

Solid waste from transit mixture washing, muck (debris/sludge) generated from RMC shall either be reused through recovery unit/ Reclaiming system OR disposed off at a designated approved site by local body, for debris / construction waste. Industry shall comply with following additional conditions:

1. The RMC plants where the norms are not followed and the technology is old (Star type) shall be discarded within 1 year. Existing RMC plant shall implement the suggested guidelines within a year. The renewal of Maharashtra Pollution Control Board's consent shall be considered only after implementation of new guidelines. The RMC's having valid consent of Maharashtra Pollution Control Board shall amend their consent in compliance with guideline within a year.
2. Operation of RMC plant shall be in day time only. However in notified MIDC area, notified industrial parks, outside corporation area timing are not applicable. The Day time shall mean from 6 a.m. to 10 p.m.
3. The industry strictly follows the Guidelines for Ready Mix Concrete Plant (RMC) for sitting criteria of RMC Plant in the State of Maharashtra as per notification dated 7/11/2016.

SCHEDULE-III

Details of Bank Guarantees:

Sr. No	Consent (C2E/C2O/C2R)	Amt of BG Imposed	Submission Period	Purpose of BG	Compliance Period	Validity Date
NA						

BG Forfeiture History

Srno.	Consent (C2E/C2O/C2R)	Amount of BG imposed	Submission Period	Purpose of BG	Amount of BG Forfeiture	Reason of BG Forfeiture
NA						

BG Return details

Srno.	Consent (C2E/C2O/C2R)	BG imposed	Purpose of BG	Amount of BG Returned
NA				



SCHEDULE-IV

General Conditions:

1. The Energy source for lighting purpose shall preferably be LED based
2. The PP shall harvest rainwater from roof tops of the buildings and storm water drains to recharge the ground water and utilize the same for different industrial applications within the plant
3. Conditions for D.G. Set
 - a) Noise from the D.G. Set should be controlled by providing an acoustic enclosure or by treating the room acoustically.
 - b) Industry should provide acoustic enclosure for control of noise. The acoustic enclosure/ acoustic treatment of the room should be designed for minimum 25 dB (A) insertion loss or for meeting the ambient noise standards, whichever is on higher side. A suitable exhaust muffler with insertion loss of 25 dB (A) shall also be provided. The measurement of insertion loss will be done at different points at 0.5 meters from acoustic enclosure/room and then average.
 - c) Industry should make efforts to bring down noise level due to DG set, outside industrial premises, within ambient noise requirements by proper siting and control measures.
 - d) Installation of DG Set must be strictly in compliance with recommendations of DG Set manufacturer.
 - e) A proper routine and preventive maintenance procedure for DG set should be set and followed in consultation with the DG manufacturer which would help to prevent noise levels of DG set from deteriorating with use.
 - f) D.G. Set shall be operated only in case of power failure.
 - g) The applicant should not cause any nuisance in the surrounding area due to operation of D.G. Set.
 - h) The applicant shall comply with the notification of MoEFCC, India on Environment (Protection) second Amendment Rules vide GSR 371(E) dated 17.05.2002 and its amendments regarding noise limit for generator sets run with diesel.
4. The applicant shall maintain good housekeeping.
5. The non-hazardous solid waste arising in the factory premises, sweepings, etc. be disposed of scientifically so as not to cause any nuisance / pollution. The applicant shall take necessary permissions from civic authorities for disposal of solid waste.
6. The applicant shall not change or alter the quantity, quality, the rate of discharge, temperature or the mode of the effluent/emissions or hazardous wastes or control equipments provided for without previous written permission of the Board. The industry will not carry out any activity, for which this consent has not been granted/without prior consent of the Board.
7. The industry shall ensure that fugitive emissions from the activity are controlled so as to maintain clean and safe environment in and around the factory premises.
8. The industry shall submit quarterly statement in respect of industries obligation towards consent and pollution control compliance's duly supported with documentary evidences (format can be downloaded from MPCB official site).
9. The industry shall submit official e-mail address and any change will be duly informed to the MPCB.
10. The industry shall achieve the National Ambient Air Quality standards prescribed vide Government of India, Notification No. B-29016/20/90/PCI-L dated. 18.11.2009 as amended.
11. The Board reserves its rights to review plans, specifications or other data relating to plant setup for the treatment of waterworks for the purification thereof & the system for the disposal of sewage or trade effluent or in connection with the grant of any consent conditions. The Applicant shall obtain prior consent of the Board to take steps to establish the unit or establish any treatment and disposal system or an extension or addition thereto.

12. The industry shall ensure replacement of pollution control system or its parts after expiry of its expected life as defined by manufacturer so as to ensure the compliance of standards and safety of the operation thereof.
13. The PP shall provide personal protection equipment as per norms of Factory Act
14. Industry should monitor effluent quality, stack emissions and ambient air quality monthly/quarterly.
15. Whenever due to any accident or other unforeseen act or even, such emissions occur or is apprehended to occur in excess of standards laid down, such information shall be forthwith Reported to Board, concerned Police Station, office of Directorate of Health Services, Department of Explosives, Inspectorate of Factories and Local Body. In case of failure of pollution control equipments, the production process connected to it shall be stopped.
16. The applicant shall provide an alternate electric power source sufficient to operate all pollution control facilities installed to maintain compliance with the terms and conditions of the consent. In the absence, the applicant shall stop, reduce or otherwise, control production to abide by terms and conditions of this consent.
17. The industry shall recycle/reprocess/reuse/recover Hazardous Waste as per the provision contain in the Hazardous and Other Wastes (M & TM) Rules 2016, which can be recycled /processed /reused /recovered and only waste which has to be incinerated shall go to incineration and waste which can be used for land filling and cannot be recycled/reprocessed etc. should go for that purpose, in order to reduce load on incineration and landfill site/environment.
18. An inspection book shall be opened and made available to the Board's officers during their visit to the applicant.
19. Industry shall strictly comply with the Water (P&CP) Act, 1974, Air (P&CP) Act, 1981 and Environmental Protection Act, 1986 and industry specific standard under EP Rules 1986 which are available on MPCB website (www.mpcb.gov.in).
20. Separate drainage system shall be provided for collection of trade and sewage effluents. Terminal manholes shall be provided at the end of the collection system with arrangement for measuring the flow. No effluent shall be admitted in the pipes/sewers downstream of the terminal manholes. No effluent shall find its way other than in designed and provided collection system.
21. Neither storm water nor discharge from other premises shall be allowed to mix with the effluents from the factory.
22. The industry should not cause any nuisance in surrounding area.
23. The industry shall take adequate measures for control of noise levels from its own sources within the premises so as to maintain ambient air quality standard in respect of noise to less than 75 dB (A) during day time and 70 dB (A) during night time. Day time is reckoned in between 6 a.m. and 10 p.m. and night time is reckoned between 10 p.m. and 6 a.m.
24. The industry shall create the Environmental Cell by appointing an Environmental Engineer, Chemist and Agriculture expert for looking after day to day activities related to Environment and irrigation field where treated effluent is used for irrigation.
25. The applicant shall provide ports in the chimney/(s) and facilities such as ladder, platform etc. for monitoring the air emissions and the same shall be open for inspection to/and for use of the Board's Staff. The chimney(s) vents attached to various sources of emission shall be designated by numbers such as S-1, S-2, etc. and these shall be painted/ displayed to facilitate identification.

26. The industry should comply with the Hazardous and Other Wastes (M & TM) Rules, 2016 and submit the Annual Returns as per Rule 6(5) & 20(2) of Hazardous and Other Wastes (M & TM) Rules, 2016 for the preceding year April to March in Form-IV by 30th June of every year.
27. The applicant shall install a separate meter showing the consumption of energy for operation of domestic and industrial effluent treatment plants and air pollution control system. A register showing consumption of chemicals used for treatment shall be maintained.
28. The applicant shall bring minimum 33% of the available open land under green coverage/ plantation. The applicant shall submit a yearly statement by 30th September every year on available open plot area, number of trees surviving as on 31st March of the year and number of trees planted by September end.
29. The Board reserves its rights to review plans, specifications or other data relating to plant setup for the treatment of waterworks for the purification thereof & the system for the disposal of sewage or trade effluent or in connection with the grant of any consent conditions.
30. The firm shall submit to this office, the 30th day of September every year, the Environment Statement Report for the financial year ending 31st March in the prescribed FORM-V as per the provisions of Rule 14 of the Environment (Protection) (second Amendment) Rules, 1992.
31. The Applicant shall obtain necessary prior permission for providing additional control equipment with necessary specifications and operation thereof or alteration or replacement/alteration well before its life come to an end or erection of new pollution control equipment.
32. The Board reserves its rights to vary all or any of the condition in the consent, if due to any technological improvement or otherwise such variation (including the change of any control equipment, other in whole or in part is necessary).
33. The applicant shall provide facility for collection of environmental samples and samples of trade and sewage effluents, air emissions and hazardous waste to the Board staff at the terminal or designated points and shall pay to the Board for the services rendered in this behalf.

This certificate is digitally & electronically signed.
